

CryoVEx

Airborne Data Products Description

Prepared by: Robert Cullen

Checked by:

Approved by:

•
ESTEC
Noordwijk
The Netherlands



Ref.:CS-LI-ESA-GS-0371

Issue: 2.6

Date: 01/06/2009

Page: 2 / 119

DOCUMENT SIGNATURE PAGE

	Name & Function	Date	Signature
Prepared by:	Robert Cullen	25/5/2009	
Checked by:			
Approved by:			
Approved by:			

DOCUMENT CHANGE RECORD

Iss./Rev.	Date	Page	Observations
Draft A	27 Jan 2003	All	Initial draft
Draft B	20 Oct 2004	All	All products updated – Not checked
Draft C	25 Nov 2004	§2.1.3 §3.1.5 §3.2.2	Update whilst fog-bound at Schiphol.
V1.0	1 April 2005	All	Release applicable to version 2.00 of the ASIRAS processor.
Draft v1.1	15 th April 2005	§3.2.4 §A4	Descriptions improved Aircraft ref frame labels corrected
V1.2	20 July 2005	§3.2.4	Format change: - Add OCOG width to Measurement group - Add roll, pitch and yaw standard deviation to Measurement group - MCD update for roll, pitch and yaw thresholds
V1.3	25 th Oct 2005	All	Update for ASIRAS software version 3.02
V1.4	09/Nov 2005	Table 3-19 Table 3-24 All Table 3-18 Table 3-19 Others	LAM mode 4096 samples OCOG Re-tracker flag & Threshold Re-tracker flag added Table numbers added/ Some figure numbers added Re-tracker descriptions changed and typos corrected

Iss./Rev.	Date	Page	Observations
			<p>Re-tracker descriptions changed and typos corrected</p> <p>See change bars</p>
V1.5	17/11/2005	All level 4 §1.4 Table 3-23 §3.2.6.3 §3.2.6.5 §4	<p>Section naming improved</p> <p>File naming standard for L1b added</p> <p>MCD_ACQ added</p> <p>Position of instrumentaion file added (AUX_POSITI)</p> <p>Corner reflector position file added (AUX_TRANSP)</p> <p>Ref frames description improved</p>
V1.5.1	17/11/2005	§1.4	File naming standard for L1b improved
V1.5.2	08/12/2005	§3.2.4 §4.3	<p>Missing Noise power parameter in measurement group added.</p> <p>Note: Total sizes for record were already correct</p> <p>AMR position values were estimated for D-CODE</p>
V1.6	13/01/2006	All	<p>Update for version 3.03 of the ASIRAS processor.</p> <p>Added level 1b header (MPH, SPH, DSD) descriptions</p>
V1.6.1	18/01/2006	§3.2.1	<p>Use of change bars was not possible due to a bug in Word.</p> <p>Comment on confusing use of HAM/LAM and SAR/SARIN.</p> <p>MPH and SPH corrected for minor errors.</p> <p>Some other minor errors corrected.</p>
V2.0	28/01/2006	§1 Table 1 Table 3.1-7 §3.1.7 §3.1.8 Table 3.2-8 Table 3.2-11 Table 3.2-12 §3.2.10 §3.2.11 §3.2.12 §5 §6	<p>change bars had to be deleted due to WP problems</p> <p>ASIRAS L1b pointer improvement</p> <p>Paragraph format change</p> <p>Table re-written</p> <p>Section added for LD90 raw data structure</p> <p>Section added for ALS raw data structure</p> <p>Missing ASIRAS SPH parameters added</p> <p>Parameter 8 format “ul”</p> <p>Parameter 8 format “ul”</p> <p>LD90 L1 format added</p> <p>ALS L1 format added</p> <p>Place marker section added for ALS derived DEM’s</p> <p>Added</p> <p>Previously §5</p>

Iss./Rev.	Date	Page	Observations
V2.1	17/03/2006	§3.1 §5 All Table 3.2.17 Fig. 4.10-1	Restructured (§3.1.4 DGPS, §3.1.4.1 DGPS binary ESA format, §3.1.4.2 ASCII DGPS AWI format, §3.1.4.3 ASCII DGPS Enhanced AWI format), (§3.1.5 INS, §3.1.5.1 INS binary ESA format) §3.1.7 becomes §3.1.6 §3.1.8 becomes §3.1.7 Section for de-sampled raw, raw ASIRAS measurement data and accompanying log files. Miscellaneous improvements Added binary DGPS job order parameters Text box removed for figure
V2.2	27/03/2006	Table 3.2-11 & Table 3.2-12 Table 3.2-2 & Table 2.3-5	Cross references corrected for fields 7, 16, 49 and 50. Correction of cross references
V2.3	04/4/2006	All	Minor formatting changes
V2.4	30/08/2006	§3.1.4.1 §3.1.5.1 §3.2.12 Tab 2.3.2.5 §3.2.4 All	Total number binary DGPS format bytes added to table Total number of binary INS format bytes added to table. Added ALS derived DEM L1B format. – verified by AWI (e-mail 29 th Aug 2006 – “Re: ALS L1b format” (Note: This is an AWI defined format and may change in the future subject to become compatible with DNSC formats) Removed LAM/HAM range calculations improved General re-formatting
V2.5	9/9/2007	All §4.3 §3.2.12 §5.7, 5.8,5.9,5.10 §5.9 §3.2.12 §2	General changes Rotation matrices corrected Question mark removed from UTC time stamp Version numbering added to non ASIRAS L1B file names ALS DEM file naming changed to indicate resolution of retrieval ALS data formats clarified for CryoVEx 2004 version 1 (§3.2.12.1) and all subsequent ALS data sets (§3.2.12.2). ASIRAS description updated. Details of where processor description information can be found has been added in §2.2



Ref.:CS-LI-ESA-GS-0371

Issue: 2.6

Date: 01/06/2009

Page: 6 / 119

Iss./Rev.	Date	Page	Observations
2.5/1.0	28/5/2008	§3.2.2 P.33	ASI_SINAL1 Increase size of echo pointers to unsigned long long. Record size increased to 172 bytes per burst.
2.6	01/6/2009	Front §5.6 Table 3.17 §3.2.5.2 All	Title change to cover all airborne data sets. Added file type ASIWL1B for windowed LAM/LAM-A Added DS names for windowed LAM Added table for ASI_LAM_W_L1B + various updates throughout the document.

TABLE OF CONTENTS

1. Introduction	13
1.1. Summary.....	13
1.2. Scope.....	13
1.3. References	13
1.4. Conventions.....	15
1.5. Acronyms and abbreviations	16
2. ASIRAS and other instrumentation relevant to data processing.....	17
2.1. Description	17
2.2. Associated instrumentation	18
2.2.1. Global Positioning (GPS)	19
2.2.2. Inertial Navigation System (INS)	19
2.2.3. Other Instrumentation	19
2.2.3.1. Laser scanner (ALS)	19
2.3. Data Processing of ASIRAS raw data	19
3. File types & Formats	22
3.1. Instrument Data Formats	23
3.1.1. ASIRAS log file (ASI_LOG_L0)	23
3.1.2. ASIRAS science measurement data (ASI_RX1_L0 & ASI_RX2_L0).....	23
3.1.3. ASIRAS Impulse Response calibration 2 data (AUXASICAL2).....	23
3.1.4. Differentially processed GPS (DGPS).....	24
3.1.4.1. ESA binary DGPS (AUXBASIGPF or AUXBASIGPR).....	24
3.1.4.2. DGPS AWI ASCII data (AUX2ASIGPF or AUX2ASIGPR)	25
3.1.4.3. Enhanced DGPS AWI ASCII data (AUX3ASIGPF or AUX3ASIGPR).....	26
3.1.5. Inertial Navigation System, (INS)	26
3.1.5.1. ESA binary attitude data (AUXBASINAV).....	26
3.1.5.2. AWI ASCII attitude data (AUX1ASINAV).....	26
3.1.6. LD90 raw data structure	27
3.1.7. ALS raw data structure	28
3.2. Processed Data Formats.....	28
3.2.1. ASIRAS Level 1 Pre-Processed Data (ASI_SIN_L1).....	28
3.2.2. ASIRAS Level 1A Pre-Processed Data (ASI_SINAL1).....	28
3.2.3. ASIRAS Stack Data (BKPSINSSSS)	32
3.2.4. ASIRAS Level 1B Processed Data (ASI_SIN_1B & ASI_LAM_1B)	35
3.2.4.1. ASIRAS Level 1b MPH Description	36
3.2.4.2. ASIRAS Level 1b Specific Product Header (SPH)	41
3.2.4.3. ASIRAS Data Set Description.....	44
3.2.5. ASIRAS Measurement Data Sets	46
3.2.5.1. ASI_SIN_L1B (ASIRAS High Altitude SARIn Mode Level 1b)	47
3.2.5.2. ASI_LAM_L1B, ASI_LAMAL1B and ASI_LAM_W_L1B (ASIRAS SAR Level 1b).....	51
3.2.6. Auxiliary Data Files	64
3.2.6.1. Instrument Characterisation Database (AUX_SIRDBF).....	64

3.2.6.2.	Geophysical Constants (geophysical_constants)	64
3.2.6.3.	Reference Instrument Position (AUX_POSITI).....	65
3.2.6.4.	IERS Bulletin B (AUX_ASIBUB).....	67
3.2.6.5.	Corner Reflector Position (AUX_TRANSP)	67
3.2.6.6.	Geocorrection files	67
3.2.7.	Calibration Files	68
3.2.8.	Job orders.....	68
3.2.9.	Processor Configuration File (Processor_Conf)	70
3.2.10.	LD90 processed data structure	70
3.2.11.	ALS processed data structure.....	70
3.2.12.	ALS Level 1b DEM format.....	72
3.2.12.1.	ASL AWI Level 1b (CryoVEx 2004 A and B version 1 data).....	72
3.2.12.2.	ALS AWI Level 1b (CryoVEx 2004 version 2 CryoVEx 2005 onwards).....	73
3.2.13.	Processed HEM data format.....	75
4.	ASIRAS Processing Reference Frames	76
4.1.	World Geodetic System (WGS-84)	76
4.2.	Global Earth Fixed Frame (GEF).....	76
4.3.	Aircraft Mechanical Reference Frame (AMR)	76
4.4.	Front GPS Reference Frame (GPS_F).....	78
4.5.	Rear GPS Reference Frame (GPS_R)	79
4.6.	Nominal Aircraft Reference Frame (NAR).....	79
4.7.	Actual Aircraft Reference Frame (AAR)	80
4.8.	Determination of ARR origin in ITRF and WGS-84 coordinates:	80
4.9.	Centre point of the ASIRAS baseline in ITRF and WGS-84 coordinates:	81
4.10.	Determination of yaw angle	81
4.11.	Description of Level 1b Interferometric baseline and real-beam bore-sight vectors described in ASIRAS data processing reference frame	82
4.12.	ASIRAS antenna reference frame with respect to AMR.....	83
4.13.	Rotation Matrices	84
4.14.	Coordinate system transforms	84
4.15.	Determination GEF coordinates from WGS-84 geodetic coordinates	84
4.16.	Cartesian ITRF to Geodetic conversion	85
5.	File Naming Conventions	88
5.1.	Campaign naming convention.....	88
5.2.	Raw ASIRAS data files	88
5.3.	De-sampled raw ASIRAS data files	88
5.4.	ASIRAS log files	88
5.5.	Measuring day naming convention	89
5.6.	ASIRAS Level 1b	89
5.7.	DGPS file naming convention.....	90
5.8.	Processed INS file convention	90
5.9.	Processed Laser Scanner file (Digital Elevation Model) naming convention.....	91
5.10.	Processed LD90 file naming convention.....	91
5.11.	Processed Helicopter electro-magnetic profiling (HEM) file naming convention.....	92



6. Auxiliary File Examples	93
6.1. Processor File Type Example (ASIRAS v04_02).	93
6.2. ASIRAS Processor Database	115

List of Tables

Table 1-1 Parameter types	15
Table 3-1 ASI_RX1_L0 and ASI_RX2_L0 binary header for first file	23
Table 3-2 Binary complex time domain sample structure	23
Table 3-3 AUXASICAL2 binary header structure	24
Table 3-4 Complex time domain sample record structure	24
Table 3-5 ESA defined DGPS binary big endian format	25
Table 3-6 DGPS record structure	25
Table 3-7 AUX1ASINAV INS attitude record structure	27
Table 3-8 LD90 raw data structure	27
Table 3-9 ASIRAS Level 1 ASCII Header definition	28
Table 3-10 ASI_SINAL1 record structure	30
Table 3-11 Level 1 Instrument Configuration Flags structure	31
Table 3-12 Level 1A Measurement confidence data (MCD) structure.	32
Table 3-13 Stack data record structure	33
Table 3-14 ASIRAS MPH	36
Table 3-15 ASIRAS SPH description	41
Table 3-16 ASIRAS DS NAMES for L1b measurement products	46
Table 3-17 ASIRAS DS NAMES for reference DSDs	46
Table 3-18 ASI_SIN_L1B record structure	47
Table 3-19 ASI_LAM_L1B (ASILL1B) record format. <i>This format will become obsolete for and following 2009 re-processing (See Table 3-21)</i>	51
Table 3-20 LAM-A-SAR (ASIAL1B) <i>(Not used in re-processing : See Table 3-21)</i>	53
Table 3-21 ASI_LAM_W_L1B (ASIWL1B) Used for 2009 re-processing and all subsequent campaigns)	55
Table 3-22 Instrument Configuration Flags	59
Table 3-23 Level 1b MCD structure	61
Table 3-24 Waveform group flags	62
Table 3-25 Stack beam behaviour parameters	63
Table 3-26 Level 1 Job order fields	68
Table 3-27 Level 1b Job order fields	69
Table 3-28 LD90 processed data record structure	70
Table 3-29 ALS Level_L1 data structure (obtained from AWI)	70
Table 3-30 HEM data format.	75
Table 4-1 Approximate locations for instrumentation on AWI/DLR DCODE	77
Table 5-1 Campaign naming convention (e.g. ASIRAS_04_02)	88
Table 5-2 Measuring day naming convention	89
Table 5-3 ASIRAS Level 1b file naming convention	89
Table 5-4 Example file names	89



Table 5-5 GPS file naming convention (e.g. GPS_R_20040914T144202_185324_0001.DBL).....90

Table 5-6 INS file naming convention (e.g. INS_20040914T144202_185324_0001.DBL).....90

Table 5-7 Scanner file naming convention (e.g. ALS_L1B_A1_020040914T140350_160550_0001.DBL).....91

Table 5-8 LD90 file naming convention (e.g. LD90_L1B_20040914T144202_185324_0001.DBL)91

List of Figures

Figure 2-1 ASIRAS system	17
Figure 2-2 The science modes of ASIRAS as described in [R12]. The original design in 2002 provided a SARIn mode and experimental enhanced mode that operated between aircraft elevations of ~1000 and 7000 meters and this mode has become known as HAM-SARIn. Elevations less than ~1000 m are not possible in this mode due to a restriction of design and the minimum uncompressed radar pulse length. As can be seen in the schematic laser scanners, in general operate, at elevations less than ~ 800 meters and hence coincident acquisitions between ASIRAS and ALS could only be made possible by two passes of any target at the two respective aircraft elevations. In 2005 a new mode low altitude mode SAR (LAM-SAR) was implemented and tested in a Bay of Bothnia campaign during March 2005 allowing usage in lower elevation (yellow). Large data volumes are inherent in the LAM-SAR and hence in 2007 a sub mode LAM-A-SAR was implemented and tested which successfully reduces the data volumes by a factor 4 by reducing range window size (blue). Elevation ranges are selected in LAM by switching frequency offsets (yellow and blue boxes) that re-align the anti alias filter.....	18
Figure 2-3 High level diagram of ASIRAS HAM-SARIn, LAM-SAR and LAM-A-SAR processors and file interfaces.....	21
Figure 3-1 High level ASIRAS processor diagram.....	22
Figure 3-2 ASIRAS level 1b product header. Note that only one data set record is available for ASIRAS.....	36
Figure 3-3 ASIRAS L1b record structure.....	47
Figure 4-1 Positional information regarding instrumentation on Dornier DCODE	77
Figure 4-2 Aircraft mechanical reference frame diagram	78
Figure 4-3. Yaw angle with respect to true heading of aircraft.....	81
Figure 4-4 In order to remain compatible with CryoSat L1b products the baseline and real beam vectors are described with respect to the CPRF axes. Note: In the nominal configuration the transmit only antenna is on the right hand side if observing the front of the aircraft from the center location between the two antennas. The receive only antenna is on the left hand side. Also note the $\hat{\mathbf{z}}_c$ axis points into the page and is defined as the cross product between $\hat{\mathbf{y}}_c$ and $\hat{\mathbf{x}}_c$	83

1. Introduction

This document describes the pre CryoSat-2 launch CryoVEx multi platform airborne instrumentation and associated raw and processed data products.

Specifically the document describes each of the data files generated from the ASIRAS radar altimeter and other associated airborne instrumentation required for processing ASIRAS science and calibration data.

Note:

The file formats definition for ASIRAS Level 1b is described in §3.2.4.

The format of Digital Elevation Models derived from aircraft laser scanner is described §3.2.12.

The Helicopter EM bird data format is provided in §3.2.13.

1.1. Summary

The aim of this document is to provide users of either the raw or processed ASIRAS data, and that of associated instrumentation (in particular DGPS, INS, laser scanner, HEM), a detailed format description in a single document.

The file formats for all file types relevant to the data processing of ASIRAS science data are also described and other file formats are provided in most cases. In some cases file formats are not available or are poorly described in existing manufacturing documentation, in these cases a minimum description is provided and all known documentation is referenced.

In cases where data file formats are outside ESA control and are currently undefined by industry a list of file parameters are provided with a description if they are known.

With respect to ASIRAS this version of the document is applicable to version 04.02 of the ASIRAS Level 1 and 1b processors and represents the ASIRAS hardware as of the date 01/01/2009.

Note regarding ASIRAS level 1b file format: It was an original intention to attempt to maintain the CryoSat level 1b product format for use with ASIRAS however the products required changes due to differences between the SIRAL and ASIRAS instrumentation and the need to add additional parameters to assist with the interpretation of the low altitude derived airborne data.

It should be noted that ESA has not developed a level 2 processor for ASIRAS and only distributes the L1b data in this respect.

1.2. Scope

This document describes the processed level 1,1A and 1b data products and associated auxiliary data files for ASIRAS, laser scanner and EM bird instruments.

A description of the changes between ASIRAS level 1A and 1B processors with respect to the CryoSat counterpart are provided in §2.3.

This document does not describe science data processing methods for instrumentation; one should identify campaign reports in the following references section for that purpose.

1.3. References

[R1] IEEE Standard for Binary Floating-Point Arithmetic. ANSI/IEEE Std 754-1985 Institute of Electrical and Electronics Engineers. Issued 1985.

[R2] CryoVex 2004 data acquisition and processing progress report, ESA Contract C18677/04/NL/GS. 22nd February 2006.

- [R3] Earth explorer file format guidelines, CS-TN-ESA-GS-0154, Issue 1.4, 13th June 2003.
- [R4] Honeywell Lasernav Inertial navigation system installation manual, 95-8114, 15 April 1983. Revised 15 May 1985.
- [R5] International Earth Rotation Service Bulletin B explanatory supplement. August 2004, <http://hpiers.obspm.fr/eop-pc/>
- [R6] International Earth Rotation Service Conventions 2003, <http://tai.bipm.org/iers/conv2003/conv2003.html>
- [R7] World Geodetic System 1984, <http://www.wgs84.com>
- [R8] RIEGL LMS-Q280 Airborne Laser Scanner technical documentation and users instructions.
- [R9] Raney, R. K. and Jensen, J. R., 2000, "D2P project: Test campaign results" <http://fermi.jhuapl.edu/d2p/>, June 2000.
- [R10] Technical support for the deployment of radar and laser altimeters during LaRa 2002, R. K. Raney and C Leuschen, Johns Hopkins University March 2003
- [R11] Airborne Lidar and Radar measurements over sea ice and inland ice for CryoSat validation: CryoVEx 2003 – Final Report, K. Keller et al, National Survey and Cadastre, 2004.
- [R12] ASIRAS Design Description. ASIRAS-RST-ADD-0001, version 2. 23/04/2007.
- [R13] ASIRAS Operational Manual, ASIRAS-RST-MA-0002, version 2, 24/04/2007.
- [R14] ASIRAS Quicklook viewer user manual, ASIRAS-RST-MA-0001 version 2. 18/04/2007.
- [R15] ASIRAS Test report for pre-campaign, ASIRAS-RST-TR-0014, version 1. 27/03/2007.
- [R16] ASIRAS Laboratory test report for ASIRAS upgrades, ASIRAS-RST-AG-07017. 17/04/2007.
- [R17] ASIRAS In-flight test report for ASIRAS upgrades, ASIRAS-RST-AG-07018. 17/04/2007.
- [R18] ASIRAS Operator procedure list, ASIRAS-RST-LI-0001, issue 3, 29/3/2007
- [R19] Mavrocordatos, C., Attema, E., Davidson, M., Lenz, H. and Nixdorf, U., 2004, "Development of ASIRAS (Airborne SAR/Interferometric Altimeter System)", *Proc. IGARSS 2004 Symposium*.
- [R20] Lentz, H., Braun, H., Younis, N., Fischer, C., Wiesbeck, W. and Mavrocordatos, C., "Concept and realisation of an airborne SAR/interferometric radar altimeter system", in *Proc. IGARSS 2002 symposium*.
- [R21] Hawley, R. L., Morris, E. M., Cullen, R., Nixdorf, U., Shepherd, A. P and Wingham, D. J., 2006, "ASIRAS airborne radar resolves internal annual layers in the dry-snow zone of Greenland", *Geophys. Res. Lett.* Vol. 33. No. 4. L04502, doi:10.1029/2005GL025147.
- [R22] Helm, V., W. Rack, R. Cullen, P. Nienow, D. Mair, V. Parry, and D. J. Wingham (2007), Winter accumulation in the percolation zone of Greenland measured by airborne radar altimeter, *Geophys. Res. Lett.*, Vol. 34, L06501, doi:10.1029/2006GL029185
- [R23] CryoSat Instrument Processing Facility Level 1b, Product formats specification, CS-RS-ACS-GS-5106 issue 3.1 24/06/2006.
- [R24] Wingham, D. J., Francis, C. R., Baker, S., Bouzinac, C., Brockley, D., Cullen, R., de Chateau-Thierry, P., Laxon, S. W., Mallow, U., Mavrocordatos, C., Phalippou, L., Ratier, G., Rey, L., Rostan, F., Viau, P. and Wallis, D., 2006, "CryoSat: A Mission to Determine the Fluctuations in Earth's Land and Marine Ice Fields", *Advances in Space Research*, Vol. 36, pp. 841-871. doi:10.1016/j.asr.2005.07.027
- [R25] Wingham, D. J., Phalippou, L., Mavrocordatos, C. and Wallis, D., 2004 "The mean echo and echo cross-product from a beam forming, interferometric altimeter and their application to elevation measurement", *IEEE Trans. Geoscience and Remote Sensing*, Vol. 42, No. 10, pp. 2305-2323. doi 10.1109/TGRS.2004.834352
- [R26] Cullen, R., and Wingham, D.J., "CryoSat level 1b processing algorithms and simulation results", *IGARSS 2002*.
- [R27] CryoSat IPF1 ESL design summary document, CS-DD-MSL-GS-0008 issue 2.3 4th Sept 2003.
- [R28] CryoVEx 2004 and Bay of Bothnia 2005 campaign final report, V. Helm, S. Hendricks, S. Goebell, T. Boebel, W. Rack, C. Haas and U. Nixdorf, Alfred Wegner Institute, ESA contract C18677/04/NL/GS.

- [R29] CryoVEx 2005 (Bay of Bothnia) redistribution report, Nov. 2006
- [R30] CryoVEx 2006 data acquisition report, DNSC, Aug. 2006
- [R31] CryoVEx 2006 Airborne Lidar and Radar measurements in and around Greenland, DNSC (Draft).
- [R32] CryoSat-2 interim validation implementation plan. CS-PL-ESA-SY-0265, issue 01/12/2006.
- [R33] CryoVEx 2006 operations plan spring 2006 campaign. version 1.0 10th April 2006
- [R34] ESA Spring 2007 Campaigns CryoVEx/IceSAR/BioSAR operations plan version 2, 7th March 2007.
- [R35] CryoSat IPF1 SAR/SARIn specialized processors detailed processing model, ARE_CRYO_SARSARIN_DPM. Version 5.1, 26th March 2007.
- [R36] Bamber, J. L., "Ice sheet processor scheme", *Int. J. Remote Sensing*, 15, 925-938.

1.4. Conventions

All ASIRAS related binary products are generated in big endian format [R1] in order to be compliant with the CryoSat payload data segment generated products.

Parameter types are described in the following tables.

Table 1-1 Parameter types

Type	Description	Size (bytes)
uc	Unsigned character	1
sc	Signed character	1
us	Unsigned short integer	2
ss	Signed short integer	2
ul	Unsigned long integer	4
sl	Signed long integer	4
ull	Unsigned long long integer	8
sll	Signed long long integer	8
d	Double precision floating	8
f	Single precision floating	4
[n]	Array length n	

Bit numbering:

2-byte integer: bit number 0= LSB, bit 15=MSB

4 byte integer: bit number 0=LSB, bit 31=MSB

Time:

All data should be referenced in TAI units in order to be compliant with CryoSat data products.

Timestamps is described in units of TAI with respect to 1 Jan 2000 at 00:00 (TAI). Not MJD.

File naming conventions:

See §5.

Sign conventions for corrections:

For example, if the instrument path delay=3nS the correction should be -3nS in the product.

Gain/Attenuation:

AGC is reported as an attenuation. For example, if the AGC is attenuating a signal by 6 dB the value in the product will be 6 dB.

Endian:

Raw Binary data produced by ASIRAS is in the little endian format. All data produced by the ASIRAS processor is written in the big endian format in line with CryoSat ground segment products.

Application of True Heading, Roll and Pitch

Application and convention for pointing angles are described in §4.

1.5. Acronyms and abbreviations

AAR	Actual aircraft reference frame
ALS	Riegl Laser scanner LMSQ280 (AWI) or LMS-Q140i-60 (DNSC 2006)
ASIRAS	Assessment of SAR/Interferometric radar altimeter concept
AMR	Aircraft mechanical reference frame
AWI	Alfred Wegner Institute
COB	ASIRAS centre of baseline
COM	Centre of mass
CPRF	CryoSat processing reference frame
DEM	Digital Elevation Model
DSD	Data set descriptor.
DGPS	Differential global positioning system
DNSC	Danish National Space Centre
DLR	Deutschen Zentrum für Luft- und Raumfahrt
DTU-Space	Technical University of Denmark
EGM-96	Earth Gravity model
FBR	CryoSat Full bit rate product (equivalent to ASIRAS level 1 not level 1b)
FMCW	Frequency modulated continuous wave
GNSX	INS system on DLR aircraft.
GPS	Global positioning system (manufacturers are platform dependent)
HAM-SARIn	High altitude SARIn mode
IPF	Instrument Processing Facility (CryoSat)
INS	Inertial navigation system
ITRF	International terrestrial reference frame
LAM-SAR	Low Altitude SAR mode (implemented 2005)
LAM-A-SAR	Low altitude SAR mode with reduced window size (implemented and tested 2007)
LAM-W-SAR	LAM 11b echoes windowed to 256 range samples
LD90	Riegl Laser Altimeter
LSB	Lowest significant bit
MCD	Measurement confidence data
MJD	Modified Julian date: defined as day 0 from 00:00:00 until 23:59:59 on 1 st Jan 2000.
MSB	Most significant bit
MPH	Main product header
NAR	Nominal aircraft reference frame
OCOG	Offset Centre of Gravity (a re-tracker)
PTR	Point target response
SPH	Specific product header
TBC	To be confirmed
TBD	To be determined
WGS-84	World Geodetic System of 1984 : reference ellipsoid
XML	Extensible markup language

2. ASIRAS and other instrumentation relevant to data processing

2.1. Description

The ASIRAS system design, description, operation description and laboratory testing results are described in [R12] to [R18]. The basic configuration of ASIRAS in Figure 2-1. The main functional units are

- GPS used to provide timing synchronisation.
- Radar control computer
- Radar altimeter
- Data store
- Central on-board computer.

Figure 2-1 ASIRAS system

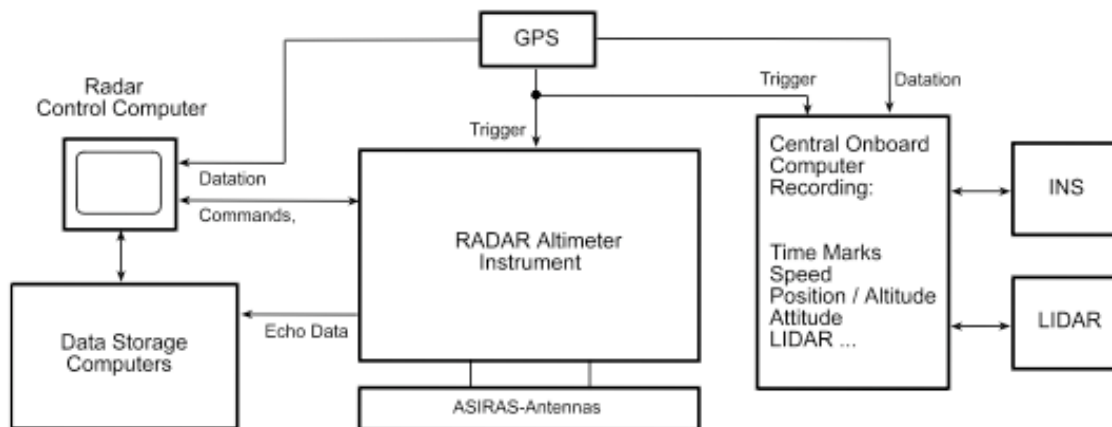

ASIRAS can be operated in a number of modes developed from its original design followed by modifications implemented in 2005 and 2007 to improve operability and later on-ground processing performance. The science acquisition modes and elevation restrictions with respect to usage of these modes are shown in Figure 2-2. The original modes of ASIRAS are the SARIn (SARIN-HAM) and Enhanced SARIn¹ which operate between elevations of about 1000 and 7000 meters with either a manual or automatic surface tracking. One key restriction with this original design is the instrument cannot be operated below 1000 meters that happens to be the elevation range for which laser scanners (§2.2.3) are best operated. The hardware change (SAR-LAM) to ASIRAS allowing operation below 1000 meters was a significant one resulting in a FMCW operation transmission through one antenna and reception via the other antenna². With this option any FMCW pulse is still being transmitted whilst simultaneously being received by the other antenna; this is a deviation from standard radar altimeter design. In order for this mode to function a frequency offset is necessary in order to re-align the anti aliasing filter (see [R12] and [R13]). This frequency offset is dependent on aircraft elevation ranges. Surface tracking in this mode is only available by manual operation.

A further hardware change reducing the large data volumes of the SAR-LAM and hence processing performance is referred to as SAR-LAM-A.

¹ Enhanced SARIn is an experimental mode for which there is no processor available.

² Thus losing interferometric capability. The purpose for choosing FMCW rather than reducing the uncompressed pulse length was due to a significant cost if the latter was to have been chosen.

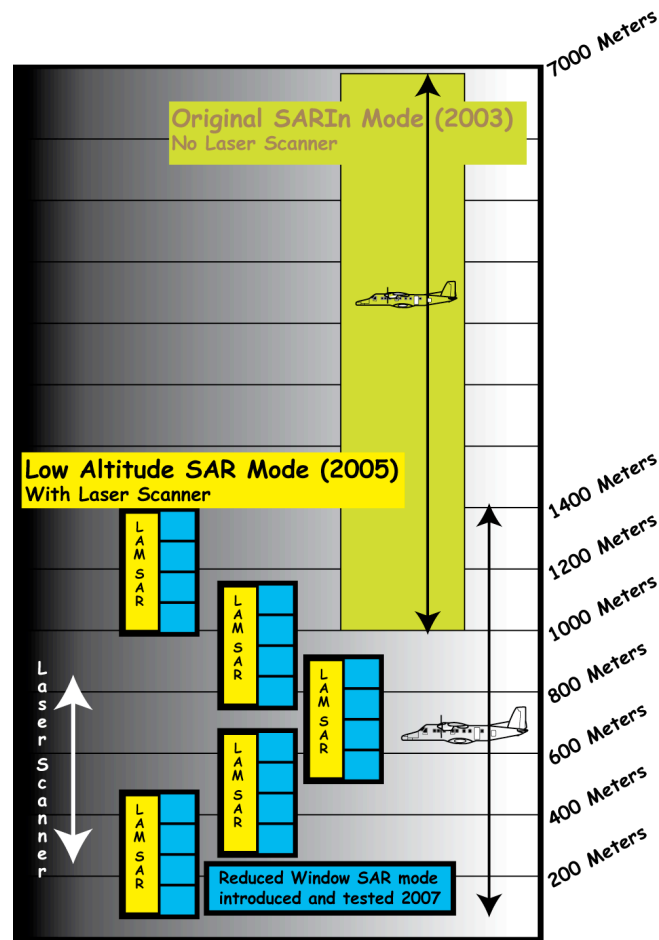

Figure 2-2 The science modes of ASIRAS as described in [R12]. The original design in 2002 provided a SARIn mode and experimental enhanced mode³ that operated between aircraft elevations of ~1000 and 7000 meters and this mode has become known as HAM-SARIn. Elevations less than ~1000 m are not possible in this mode due to a restriction of design and the minimum uncompressed radar pulse length. As can be seen in the schematic laser scanners, in general operate, at elevations less than ~800 meters and hence coincident acquisitions between ASIRAS and ALS could only be made possible by two passes of any target at the two respective aircraft elevations. In 2005 a new mode low altitude mode SAR (LAM-SAR) was implemented and tested in a Bay of Bothnia campaign during March 2005 allowing usage in lower elevation (yellow). Large data volumes are inherent in the LAM-SAR and hence in 2007 a sub mode LAM-A-SAR was implemented and tested which successfully reduces the data volumes by a factor 4 by reducing range window size (blue). Elevation ranges are selected in LAM by switching frequency offsets (yellow and blue boxes) that re-align the anti alias filter.

2.2. Associated instrumentation

There are a number of instruments associated with ASIRAS both used to assist in the processing of the ASIRAS measurement/calibration data and also with the analysis of the processed ASIRAS data. A description of this instrumentation can be found, for example in [R12] to [R20].

³ There is no processor developed for enhanced SARIn mode.

2.2.1. Global Positioning (GPS)

The GPS equipment generates the timing for the ASIRAS at the start of recording. This synchronisation is reported in the ASIRAS log file.

At a rate of 1Hz⁴ (Trimble system used by AWI, Trimble 4000-SSI on the DNSC system) the system provides aircraft location information described in the WGS-84 and the geoid height using the EGM-96 gravitational field model.

This GPS data is differentially processed with the use of a GPS base station to give the DGPS data file used by the ASIRAS L1b processor. Methods of differential processing are dependent on the operators of the relevant platform.

Differential software also differs between the AWI and DNSC implementations.

2.2.2. Inertial Navigation System (INS)

The aircraft inertial navigation system (GNSX used by AWI, Honeywell H764-G used by DNSC) generates attitude and location information. The data is not time stamped using the GPS and so synchronisation information is required in order to use this data to process the ASIRAS data. The rate of this data is 50 Hz for GNSX and TBD Hz for DNSC system.

The data also contains location information however this should not be used for ASIRAS processing for which DGPS is preferred.

Note: Convention required for roll, pitch, yaw angle application to the aircraft reference frame is described in §4.

Heading, pitch and roll angles are relative to those determined at switch on time of the instrument [R14].

At instrument switch on an initialisation procedure takes place that generates zero or reference angles (presumably) based on the instantaneous local gravity normal.

In order to improve INS parameter estimates it may be necessary, therefore, to have some knowledge of the gravity field in order to process this type of data.

2.2.3. Other Instrumentation

Other instrumentation not discussed in this document apart from file formats, however, associated with ASIRAS are the laser altimeter (LD90), meteorological equipment and video/still photography. The laser scanners adopted for operation are listed in the next section.

2.2.3.1. Laser scanner (ALS)

To date two laser scanners are available and are platform dependent. These are:

Manufacturer	Type	Description
Riegl	LMSQ280 (AWI)	[R28]
Riegl	LMS-Q140i-60 (DNSC 2006)	[R30] and[R31]

2.3. Data Processing of ASIRAS raw data

The section provides information regarding the methods of processing the ASIRAS raw data.

The ASIRAS level 1b processor is a re-build of the operational CryoSat SAR and SARIn level 1a (FBR) to level 1b that takes into account the differences of data interfaces and the quite different geometry encountered,

⁴ 1 Hz GPS may be improved in future campaigns.

differences between waveform sizes and specifics to the data acquisition. The processors carry out a very similar functionality to the CryoSat processors. Figure 2-3 shows a high level functionality of the ASIRAS processors. The ASIRAS pre-processor takes as input all relevant input files and generates a consolidated single file containing instrument location in WGS-84, burst echo datation, attitude angles and orientation vectors. In an early version of the processor echoes were actually copied into the resulting level 1 file, however, the large data volumes encountered with LAM-SAR resulted in a level 1a file definition containing echo pointers to the raw echo files. The level 1a to level 1b extracts the raw echoes by using file and file location pointers.

The ASIRAS processors are operated in an almost identical way to the CryoSat processors. On execution of either of the pre-processor programmes (HAM-SARIn [ASI_L1_], LAM-SAR [ASI_L1_LAM] or LAM-A-SAR [ASI_L1_LAMA]) or level 1a-level 1b programmes (HAM-SARIn [ASI_L1B], LAM-SAR [ASI_L1B_LAM] or LAM-A-SAR [ASI-L1B-LAMA]) a single input file to the executable is provided known as a job order. The job order provides a list of all input/output files also specifying the run-time configuration and characterisation files.

The science algorithms in the level 1b processing (see Figure 3-1) are similar to CryoSat despite a considerable difference in implementation due to the need to optimise use of memory for the ASIRAS equivalent. Differences to the CryoSat algorithms are mainly due to additional breakpoint (diagnostic files) and the implementation of one of two re-trackers. The OCOG re-tracker⁵ (a description is provided in [R36]) has been implemented to give the developer a measure of processing accuracy. This re-tracker is known to have a variable response depending on surface type and characteristics and it has been shown ([R22], for example) that a different re-tracker may be needed depending on the type of waveform encountered. All CryoVEx ASIRAS data is processed with OCOG though a threshold re-tracker is also implemented in the software and can be switched into use for testing. Average 1Hz pulse limited echoes are not produced or output into the level 1b product also geo-corrections are also not added to the ASIRAS level 1b product. The level 1b product has strong similarities to the CryoSat counterpart however it was necessary to include more information in the ASIRAS product due to sensitivity of the ASIRAS response to attitude manoeuvres, for example.

Apart from some details the CryoSat documentation available for the understanding of ASIRAS processing is provided in the following table which should be used in conjunction with relevant details contained in §3.2.4 and §4.

Reference	Title	Description
[R27]	CryoSat IPF1 ESL design summary document	Describes the high level functionality of the CryoSat level 1a (FBR) to level 1b science algorithms for SAR and SARIn modes
[R24]	CryoSat: A Mission to Determine the Fluctuations in Earth's Land and Marine Ice Fields	Paper describing the mission as a whole with the details of processing for each data level
[R35]	Level 1b detailed processing model	The same as [R27] with further details added. A draft of what will become a formal processing mode for the SAR and SARIn level 1b processing chains.
[R26]	CryoSat level 1b processing algorithms and simulation results	An IGARSS paper describing level 1b processing
[R23]	CryoSat product formats document	Details of all products for information

⁵ The on-board EnviSat RA-2 re-tracker known as the *model-free tracker* is based on the OCOG

ASIRAS HAMILAM v03.08 Processors

Figure 2-3 High level diagram of ASIRAS HAM-SARIn, LAM-SAR and LAM-A-SAR processors and file interfaces

3. File types & Formats

This section lists all file formats generated by the ASIRAS and accompanying instrumentation required for the processing of ASIRAS data to level 1b. Sub-Headings also contain the ASIRAS processor file types as described in §3.2.8.

The ASIRAS processor is shown in the next diagram showing the use of each of the file types.

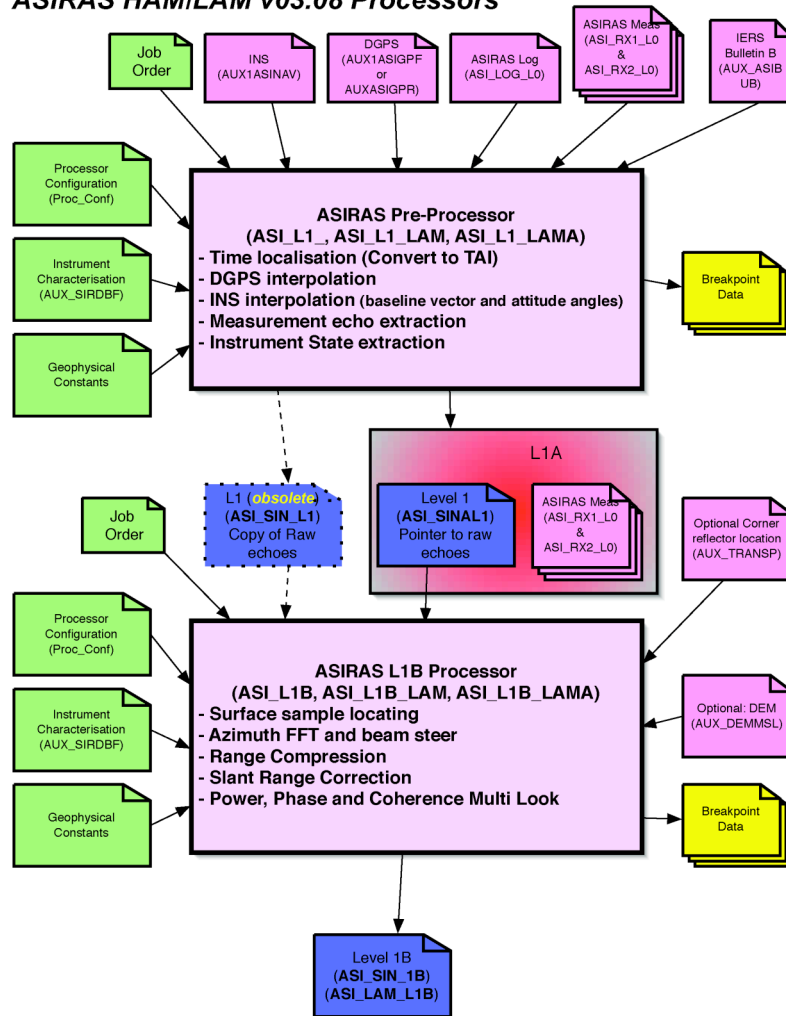
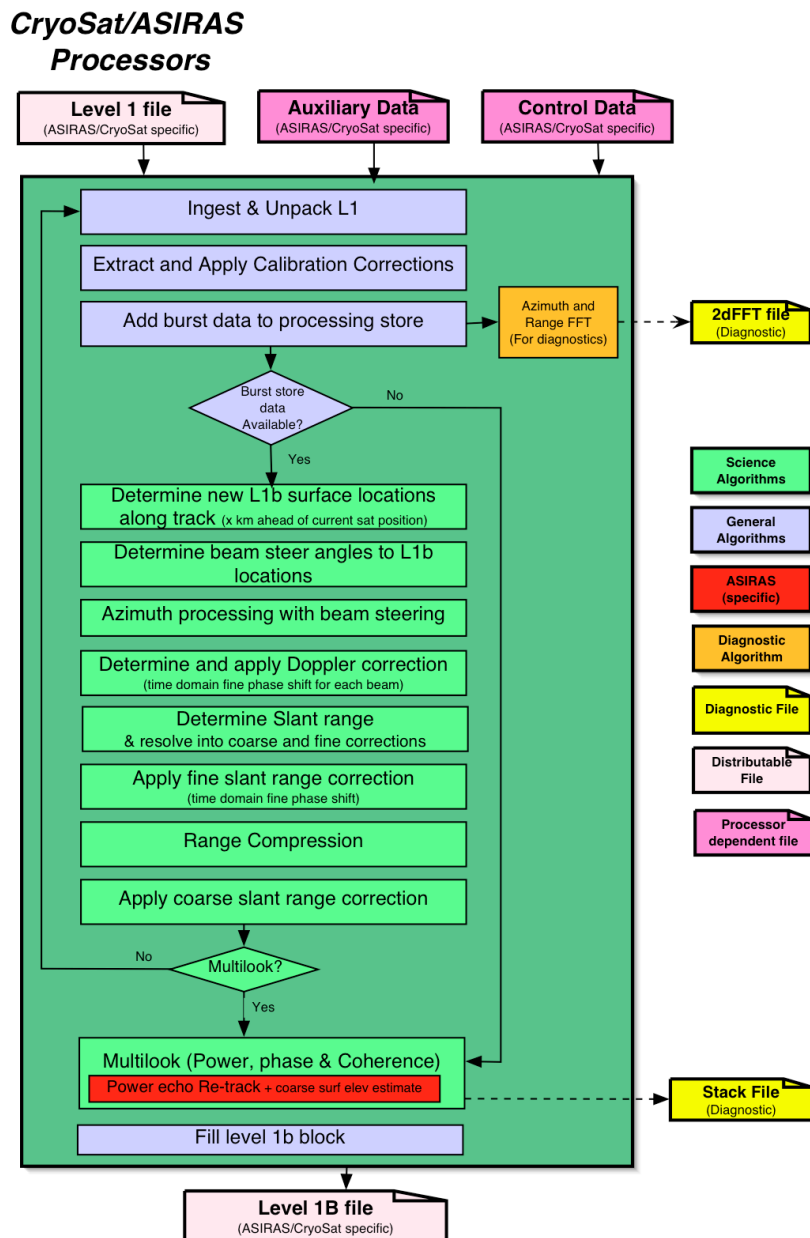

Figure 3-1 High level ASIRAS processor diagram

3.1. Instrument Data Formats

3.1.1. ASIRAS log file (ASI_LOG_L0)

A log file is generated by the ASIRAS system for the purpose of the RST quick viewer software [R14]. A list of parameters provided in the log file can be found in the operations manual, [R13]. In brief the log files contains:

1. The names of the files containing measurement data.
2. Instrument configuration filename.
3. Some run time instrument specific constants, for example, transmit pulse length.
4. Certain events during processing, for example, the time and echo number that the on-board tracker changes including the de-ramp chirp trigger delay value.
5. AGC setting changes with respect to instrument echo number

Note: ASIRAS log files before 1st Jan 2005 (CryoVex 2004, for example) and post 1st Jan 2005 (Bay of Bothnia test campaign, for example) are incompatible since for the first case the echo event counter in the log file is multiplied by a factor 8.

3.1.2. ASIRAS science measurement data (ASI_RX1_L0 & ASI_RX2_L0)

Raw ASIRAS measurement data for each receive chain (File types: Rx1=ASI_RX1_L0 , Rx2=ASI_RX2_L0) is stored in a little endian format and contains a header followed by the calibration echoes.

The binary little endian header contains the following parameters:

Table 3-1 ASI_RX1_L0 and ASI_RX2_L0 binary header for first file

Identifier	Description	Unit	Type	Size
1	Samples per echo, n	Samples	ss	2

Echo sample data for a single receive chain is stored as a continuous stream of n complex samples per echo for each echo. No direct time stamping of the echoes is available in this data file and this must be extracted from the accompanying log file (see §3.1.1).

The binary little endian format for a complex time domain sample is given by.

Table 3-2 Binary complex time domain sample structure

Identifier	Description	Unit	Type	Size
	I (real component)	Counts	ss	2
	Q Imaginary component	Counts	ss	2

A sample is repeated n times to obtain the complex time domain record for a single chain. This is repeated for all subsequent records. Science data for the another receive chain is stored in a separate file with the same format

3.1.3. ASIRAS Impulse Response calibration 2 data (AUXASICAL2)



Raw ASIRAS calibration 2 data (there are 3 calibration modes, see [R12] and [R13]) for each individual receive chain is stored in a little endian format and contains a 35 byte header followed by the calibration echoes.

The binary header (little endian) contains the following parameters:

Table 3-3 AUXASICAL2 binary header structure

Identifier	Description	Unit	Type	Size
1	Ca2 identification constant	N/A	uc	1
2	Ca2 version	N/A	uc	1
3	Hour	Hour	uc	1
4	Minute	Minutes	uc	1
5	Second	Seconds	uc	1
6	Day of month	Day	uc	1
7	Month in the year	Mon	uc	1
8	Year	Year	us	2
9	Bandwidth of chirp	MHz	us	2
10	Centre frequency of chirp	MHz	us	2
11	Pulse length	S	d	8
12	Samples per echo, n	Samples	us	2
13	Pulse repetition freq	Hz	uc	1
14	Guard Time	S	d	8
15	Alltitude	m	us	2
16	Attenuation	dB	uc	1

Echo sample data for a single receive chain are stored as a continuous stream of n (P.86 of [R12] dependent of uncompressed pulse length) complex samples per echo for each echo. No direct time stamping of the echoes is available in this data file.

The format for a complex time domain sample is given by the little endian format.

Table 3-4 Complex time domain sample record structure

Identifier	Description	Unit	Type	Size
	I (real component)	Counts	ss	2
	Q (Imaginary component)	Counts	ss	2

A sample is repeated n times to obtain the complex time domain record for a single chain. This is repeated for all subsequent records.

Calibration data for the second receive chain is stored in a separate file with the same format.

3.1.4. Differentially processed GPS (DGPS)

3.1.4.1. **ESA binary DGPS (AUXBASIGPF or AUXBASIGPR)**

ESA has defined the following big endian binary data format to assist in the processing of non AWI data sets. Spares (fields 7-10 inclusive) should be set to 0.

Table 3-5 ESA defined DGPS binary big endian format

Identifier	Description	Unit	Type	Size (Bytes)
1	Days (MJD) ⁶	UTC	sl	4
2	Seconds		ul	4
3	Microseconds		ul	4
4	Latitude (WGS-84)	10 ⁻⁷ Deg	sl	4
5	Longitude	10 ⁻⁷ Deg	sl	4
6	Geodetic ellipsoidal height	m	d	8
7	Spare 7	N/A	d	8
8	Spare 8	N/A	d	8
9	Spare 9	N/A	d	8
10	Spare 10	N/A	d	8
Total				72

3.1.4.2. DGPS AWI ASCII data (AUX2ASIGPF or AUX2ASIGPR)

AWI defined DGPS location ASCII data described as a latitude/longitude and elevation (with respect to a reference ellipsoid) vector in the WGS-84 reference frame. The data is time stamped at a rate of 1 Hz (AWI Trimble system). Also provided is the EGM-96 derived geoid height for the location. It should be noted that the front or rear aircraft GPS must be explicitly identified within the ASIRAS processor (Front=AUX2ASIGPF or Rear=AUX2ASIGPR).

Note: DGPS processing uses software developed by Trimble.

Table 3-6 DGPS record structure

Identifier	Description	Unit	Format (ASCII)	Size (chars)
1	Hours	UTC (Assumed)	hh	
2	Minutes		mm	
3	Seconds		ss	
4	Days		DD	
5	Months		MM	
6	Years		YYYY	
7	Latitude of GPS (DGPS processed w.r.t WGS-84)	Degrees	TBC: +-0.00000000 +-00.00000000 +-000.00000000	
8	Longitude (DGPS processed w.r.t WGS 84)	Degrees	TBC: +-0.00000000 +-00.00000000 +-000.00000000	
9	Geodetic Height above WGS-84 reference ellipsoid	m		

⁶ For example MJD 2306 is the date for 25th of April 2006

3.1.4.3. Enhanced DGPS AWI ASCII data (AUX3ASIGPF or AUX3ASIGPR)

Deleted. Enhanced DGPS data shall use the ESA format defined in §3.1.4.1.

3.1.5. Inertial Navigation System, (INS)

3.1.5.1. ESA binary attitude data (AUXBASINAV)

ESA has defined the following big endian binary data format to assist in the processing of non AWI data sets. Parameters highlighted in red are currently used by the ASIRAS processor (other values may be set to some nominal value (0) in order to allow processing)

Identifier	Description	Unit	Type	Size (Bytes)
1	Days (MJD)	UTC	sl	4
2	Seconds		sl	4
3	Microseconds		sl	4
4	Latitude (WGS-84)	Deg	d	8
5	Longitude	Deg	d	8
6	Ground speed [kts]	kts	d	8
7	True Track	Deg	d	8
8	True Heading	Deg	d	8
9	Wind Speed	kts	d	8
10	Wind Direction	Deg	d	8
11	Magnetic Heading	Deg	d	8
12	Pitch	Deg	d	8
13	Roll	Deg	d	8
14	Pitch Rate	Deg/s	d	8
15	Roll Rate	Deg/s	d	8
16	Yaw Rate	Deg/s	d	8
17	Body longitudinal Acceleration	g	d	8
18	Body lateral Acceleration	g	d	8
19	Body normal acceleration	g	d	8
20	Vertical Acceleration in G	g	d	8
21	Velocity Inertial Vertical	ft/min	d	8
22	Velocity North-South	kts	d	8
23	Velocity East-west	kts	d	8
			Total	172

3.1.5.2. AWI ASCII attitude data (AUX1ASINAV)

The INS AWI defined ASCII data contains time stamped (assumed to be UTC) location, speed and attitude and attitude rate information. The location data from GNSX file should not be used since it has been shown to be erroneous.

The exact ASCII format of the file is not described in any document

Note:

1. ASCII AWI INS data formats have been consistent format since the CryoVex 2004 campaign.
2. Parameters highlighted in **blue** are interpolated and placed in the level 1 and 1b files.
3. As can be seen there are a number of useful parameters in this INS file which could be useful for interpreting the ASIRAS Level 1b data.

Table 3-7 AUX1ASINAV INS attitude record structure

Identifier	Description	Unit	Resolution	Format (ASCII)
1	Mission Identifier	Counter		
2	Time String	YYYY-MM-DD hh:mm:ss		
3	Integer of Millisecond	ms		
4	Latitude [°]	+180°	0.000172°	
5	Longitude [°]	+180°	0.000172°	
6	Ground speed [kts]	kts	0.125 kts	
7	True Track	+180°	0.0055°	
8	True Heading	+180°	0.0055°	
9	Wind Speed	kts	1 kts	
10	Wind Direction	+180°	0.7°	
11	Magnetic Heading	+180°	0.0055°	
12	Pitch	+180°	0.01°	
13	Roll	+180°	0.01°	
14	Pitch Rate	°/s	0.0015°/s	
15	Roll Rate	°/s	0.0015°/s	
16	Yaw Rate	°/s	0.0015°/s	
17	Body longitudinal Acceleration	g	0.001 g	
18	Body lateral Acceleration	g	0.001 g	
19	Body normal acceleration	g	0.001 g	
20	Vertical Acceleration in G	g	0.001 g	
21	Velocity Inertial Vertical	ft/min	1 ft/min	
22	Velocity North-South	kts	0.125 kts	
23	Velocity East-west	kts	0.125 kts	
24	GNS-X Baro corrected Altitude	ft	1ft	
25	GNS-X Latitude	+180°	0.000172°	
26	GNS-X Longitude	+180°	0.000172°	
27	GNS-X Groundspeed	kts	0.125kts	
28	GNS-X True Trak	+180°	0.0055°	
29	GNS-X True Heading	+180°	0.0055°	
30	GNS-X Wind Speed	kts	1 kts	
31	GNS-X Wind Direction True	+180°	0.05°	
32	GNS-X Magnetic Heading	+180°	0.0055°	
33	GNS-X Drift Angle	+180°	0.05°	
34	Mission Identification	Counter		

3.1.6. LD90 raw data structure

Ld90 ASCII raw data is taken directly from the MedusaP (or equivalent) sensor processor. The data is time stamped at an approximate rate of 4 Hz (MedusaP).

Table 3-8 LD90 raw data structure

Identifier	Description	Unit	Format (ASCII)	Size (chars)
1	Identifier (1)			
2	Timestamp 1 (e.g. 2004-04-19)		YYYY-MM-DD	
3	Timestamp 2 (e.g. 15:21:23)	UTC	hh:mm:ss	

4	Milli seconds		+000	
5	Range	m	+0000.000000	
6	Amplitude		+000.000000	
7	TBD	TBD	+0.000000	

3.1.7. ALS raw data structure

The raw ALS data structure is not described in this document. AWI or DNSC/DTU-Space should be consulted for further details if such data is required. The processed ALS data structure is defined in §3.2.12.2.

3.2. Processed Data Formats

This section provides file formats for pre-processed Level 1 data and processed Level 1b data.

3.2.1. ASIRAS Level 1 Pre-Processed Data (ASI_SIN_L1)

Deleted

3.2.2. ASIRAS Level 1A Pre-Processed Data (ASI_SINAL1)

The level 1A data file supercedes the Level 1 format. To avoid repeating the large raw data format file size pointers (Table 3-10)are incorporated in the level 1A file to provide position in a raw data

Table 3-9 ASIRAS Level 1 ASCII Header definition

Field #	Description	Units	Bytes	Format
#1	IDENTIFIER=	keyword	11	11*uc
	quotation mark (“)		1	uc
	Identifier string		60	60uc
	quotation mark (“)		1	uc
#2	CREATION_DATE=	keyword	14	14*uc
	quotation mark (“)		1	uc
	Data creation time of data set (not sensing time) If not used set to 27 blanks	TAI	27	dd-MMM-yyyyThh:mm:ss.uuuuuu
	quotation mark (“)		1	uc
	newline character	terminator	1	uc
#3	HEADER_LENGTH=+	Keyword	15	15*uc
	Header length nominally (0000000865)		10	%10d
	<bytes>	units	7	7*uc
	newline character	terminator	1	uc
#4	TOTAL_SIZE=+	Keyword	12	12*uc
	Total file size		20	%20d
	<bytes>	units	7	7*uc
	newline character	terminator	1	
#5	TOTAL_RECORDS=+	Keyword	15	15*uc
	Total number of records in file		10	%10d
	<Records>	units	9	9*uc
	newline character	terminator	1	



#6	SAMPLES_PER_ECHO=+	Keyword	18	18*uc
	The number of samples per echo		10	%10d
	<Samples>	units	9	9*uc
	newline character	terminator	1	
#7	ECHOES_PER_BURST=+	Keyword	18	18*uc
	The number of echoes per burst		10	%10d
	<Echoes>	units	8	8*uc
	newline character	terminator	1	1*uc
#8	PRI=+	Keyword	5	5*uc
	Pulse repetition interval in seconds		23	%.17E
	<S>		3	3*uc
	newline character	terminator	1	1*uc
#9	PROGRAMMED_PRF=+	Keyword	10	10*uc
	00000		5	%5d
	<Hz>	units	4	4*uc
	newline character	terminator	1	1*uc
#10	BANDWIDTH=+	Keyword	11	11*uc
	Receiver bandwidth		23	%.17E
	<Hz>	units	4	4*uc
	newline character	terminator	1	1*uc
#11	TX_POWER=+	Keyword	10	10*uc
	Transmit power		23	%.17E
	<W>	units	3	3*uc
	newline character	terminator	1	1*uc
#12	TOTAL_GAIN_RX_1=+	Keyword	17	17*uc
	Gain		23	%.17E
	<dB>	units	4	4*uc
	newline character	terminator	1	1*uc
#13	TOTAL_GAIN_RX_2=+	Keyword	17	17*uc
	Gain		23	%.17E
	<dB>	units	4	4*uc
	newline character	terminator	1	1*uc
#14	INTERNAL_PC=	Keyword	12	12*uc
	'+' or '-' depending on sign of correction		1	1*uc
	Internal phase correction		23	%.17E
	<Rad>	unit	5	5*uc
#15	EXTERNAL_PC=	Keyword	12	12*uc
	'+' or '-' depending on sign of correction		1	1*uc
	External phase correction		23	%.17E
	<Rad>	unit	5	5*uc
#16	SPARE_08=+	Keyword	10	10*uc
	0.00000000000000000000E+01		23	%.17E
	<TBD>	units	5	5*uc
	newline character	terminator	1	1*uc
#17	DESAMPLE=+	Keyword	10	10*uc
	0.00000000000000000000E+01		23	%.17E
	<TBD>	units	5	5*uc
	newline character	terminator	1	1*uc
#18	PULSELEN=+	Keyword	10	10*uc
	0.00000000000000000000E+01		23	%.17E
	<TBD>	units	5	5*uc



	newline character	terminator	1	1*uc
#19	SPARE 09=+	Keyword	10	10*uc
	0.0000000000000000E+01		23	%.17E
	<TBD>	units	5	5*uc
	newline character	terminator	1	1*uc
#20	SENSING_START=	keyword	14	14*uc
	quotation mark (“)		1	uc
	UTC start time of data sensing. This is the TAI start time of the Input Level 1B/L2 Product. If not used set to 27 blanks	TAI	27	dd-MMM-yyyy hh:mm:ss.uuuuuu
	quotation mark (“)		1	uc
	newline character	terminator	1	
#21	SENSING_STOP=	keyword	13	13*uc
	quotation mark (“)		1	uc
	UTC stop time of data sensing. This is the TAI stop time of the Input Level 1B/L2 Product. If not used set to 27 blanks	TAI	27	dd-MMM-yyyy hh:mm:ss.uuuuuu
	quotation mark (“)		1	uc
	newline character	terminator	1	
	TOTAL		891	

An example ASIRAS L1A ASCII header is provided below:

```
IDENTIFIER="ASIRAS L1 Header"
CREATION_DATE="19-Jan-2005T09:46:14:000000"
HEADER_LENGTH=+0000000865<bytes>
TOTAL_SIZE=+0000000000351380675<bytes>
TOTAL_RECORDS=+0000009343<Records>
SAMPLES_PER_ECHO=+000000224<Samples>
ECHOES_PER_BURST=+000000128<Echoes>
PRI=+2.49926019580037223E-04<S>
PROGRAMMED_PRF=+02500<Hz>
BANDWIDTH=+1.0000000000000000E+09<Hz>
TX_POWER=+5.0000000000000000E+00<W>
TOTAL_GAIN_RX_1=+0.0000000000000000E+00<dB>
TOTAL_GAIN_RX_2=+0.0000000000000000E+00<dB>
INTERNAL_PC=+0.0000000000000000E-00<Rad>
EXTERNAL_PC=+0.0000000000000000E+00<Rad>
SPARE_08=+0.0000000000000000E+00<TBD>
DESAMPLE=+0.0000000000000000E+00<Ech>
PULSELEN=+8.0000000000000065E-05<Sec>
SPARE_09=+0.0000000000000000E+00<TBD>
SPARE_10=+0.0000000000000000E+00<TBD>
SENSING_START="14-SEP-2004 16:32:29.000000"
SENSING_STOP="14-SEP-2004 16:38:34.698000"
```

Table 3-10 ASI_SINAL1 record structure

Identifier	Description	Unit	Type	Size
1	Days	TAI	sl	4
	Seconds		ul	4
	Microseconds		ul	4
2	Mode ID=0		us	2
3	Spare		us	2
4	Instrument Configuration	Table 3-11	ul	4
5	MCD	Table 3-12	ul	4
6	Echo counter		ull	8

7	Burst counter		ul	4
8	Latitude	10^{-7} Deg	sl	4
9	Longitude	10^{-7} Deg	sl	4
10	Centre of baseline geodetic elevation	10^{-3} m	sl	4
11	COB altitude rate derived from DGPS	10^{-6} m/s	sl	4
12	Aircraft velocity derived from DGPS described in ITRF (x)	10^{-6} m/s	sl	4
	(y)	10^{-6} m/s	sl	4
	(z)		sl	4
13	Real antenna beam direction vector [x,y,z]	10^{-6} m	sl	3*4
14	Interferometer baseline [x,y,z]	10^{-6} m	sl	3*4
15	Roll	10^{-6} Deg	sl	4
16	Pitch	10^{-6} Deg	sl	4
17	Yaw	10^{-6} Deg	sl	4
18	Heading	10^{-6} Deg	sl	4
19	ITRF X component position of ASIRAS centre of baseline	10^{-6} m	sll	8
20	ITRF Y	10^{-6} m	sll	8
21	ITRF Z	10^{-6} m	sll	8
22	Window delay	10^{-12} S	ull	8
23	AGC channel 1 setting	dB	sl	4
24	AGC channel 2 setting	dB	sl	4
25	ASIRAS centre of baseline to general instrument reference point range correction	10^{-6} m	sl	4
26	Measurement file number channel 1	File (starts at 0)	sl	4
27	Echo pointer in file ch 1	Echo	ull	8
28	Measurement file number channel 2	File (starts at 0)	sl	4
29	Echo pointer in file ch 2. If LAM this will have the same value as channel 1.	Echo	ull	8
			Total 172 bytes per burst	

Further parameter descriptions:

Table 3-11 Level 1 Instrument Configuration Flags structure

Bit Number	Label	Description
0	L1A_IST_SP00	Not used
1	L1A_IST_SP01	Not used
2	L1A_IST_SP02	Not used
3	L1A_IST_SP03	Not used
4	L1A_IST_SP04	Not used
5	L1A_IST_SP05	Not used
6	L1A_IST_SP06	Not used
7	L1A_IST_SP07	Not used

8	L1A_IST_SP08	Not used
9	L1A_IST_SP09	Not used
10	L1A_IST_SP10	Not used
11	L1A_IST_SP11	Not used
12	L1A_IST_SP12	Not used
13	L1A_IST_SP13	Not used
14	L1A_IST_SP14	Not used
15	L1A_IST_SP15	Not used

Table 3-12 Level 1A Measurement confidence data (MCD) structure.

Bit Number	Label	Description
0	L1A_MCD_BLOCK_DEG	Block degraded if L1A_MCD_ACQUISITION or L1A_MCD_ALT_RATE are set
1	L1A_MCD_01	Not used
2	L1A_MCD_02	Not used
3	L1A_MCD_BAD_WD	If=1 the window delay is erroneous
4	L1A_MCD_ACQUISITION	If=1 Instrument was in acquisition mode.
5	L1A_MCD_ALT_RATE	If=1 the altitude rate is > 1.5 meters per second.
6	L1A_MCD_06	Not used
7	L1A_MCD_07	Not used
8	L1A_MCD_08	Not used
9	L1A_MCD_09	Not used
10	L1A_MCD_10	Not used
11	L1A_MCD_11	Not used
12	L1A_MCD_12	Not used
13	L1A_MCD_13	Not used
14	L1A_MCD_14	Not used
15	L1A_MCD_15	Not used
16	L1A_MCD_16	Not used
17	L1A_MCD_17	Not used
18	L1A_MCD_18	Not used
19	L1A_MCD_19	Not used
20	L1A_MCD_20	Not used
21	L1A_MCD_21	Not used
22	L1A_MCD_22	Not used
23	L1A_MCD_23	Not used
24	L1A_MCD_24	Not used
25	L1A_MCD_25	Not used
26	L1A_MCD_26	Not used
27	L1A_MCD_27	Not used
28	L1A_MCD_28	Not used
29	L1A_MCD_29	Not used
30	L1A_MCD_30	Not used
31	L1A_MCD_31	Not used

3.2.3. ASIRAS Stack Data (BKPSINSSSS)

The stack data file (File type BKPSINSSSS) contains a range of data prior to multi-looking. It contains all time stamped complex beam waveforms, stack characterisation parameters, range corrections per beam and some localisation information. This data is not systematically distributed to CVRT.

Each record varies per stack and is dependent of the following variable and fixed parameters

N_{ex}	Number of extended range window samples
N_{cb}	Number of contributing beams
N_{ss}	Number of beams in sub-stack
N_s	Number of nominal mode range window samples
N_c	Number of mode chains (=1 for degraded SARIn)

The record size is determined by:

$$4(153 + N_{cb} + N_s + 2N_{ss} + N_{ss}N_s + 2N_{ex}N_c)$$

The binary big endian record structure definition is provided in the following table. □

Table 3-13 Stack data record structure

Id	Symbol	Description	Unit	Type	Size
Binary header					
1		Days	TAI	sl	4
2		Seconds	TAI	d	8
3	N_a	Sample Number of the multi-look echo		sl	4
4	N_s	Number of nominal mode range window samples		sl	4
5	N_{ex}	Number of extended range window samples		sl	4
6	N_b	Number of echoes per burst		sl	4
7	N_c	Number of mode chains(=1 for degraded SARIn)		sl	4
8		Mode=2		sl	4
9	N_{cb}	Number of contributing beams		sl	4
10	N_{ss}	Number of beams in sub-stack		sl	4
Stack Characterisation					
11		Top hat fit flag	TBC	ul	4
12		Fit sum of squares	TBD	f	4
13		Fit sum of quads	TBD	f	4
14		Fit amplitude	Watts	f	4
15	α	Fit Width	beams	f	4
16		$2\alpha^2$		f	4
17		$\alpha/2$		f	4

18		Fit centre	beams	f	4
19		Skewness	unitless	f	4
20		Kurtosis	unitless	f	4
21		Threshold used to remove stack noise	Watts	f	4
22		Sum of squares of sub-stack powers	Watts	f	4
23	μ_s	Gaussian fit mean	Beams	f	4
24	σ_s	Gaussian standard deviation	Beams	f	4
25	$\kappa[N_{cb}]$	Gaussian weights for Stack[N_{cb}] (not necessarily applied)	Unitless (normalized)	f	$4 * N_{cb}$
26	$\beta[N_s]$	Sum of weights at each range sample		f	$4 * N_s$
27	$\chi[N_{ss}]$	Range integrated power per sub-stack sample		f	$4 * N_{ss}$
28	$\gamma[N_{ss}]$	Cumulative power in χ		f	$4 * N_{ss}$
29	$\eta[100]$	Percentiles associated with γ		f	$4 * 100$
30	$P_{ss}[N_s, N_{ss}]$	Sub-stack power	Watts	f	$4 * N_s N_{ss}$
Beam group (repeated N_{cb} times)					
31		FBR burst Days	Day	sl	4
32		FBR burst Seconds	Second	ul	4
33		FBR burst Microseconds	Microsecond	ul	4
34		FBR burst ref position X	Meters	d	8
35		FBR burst ref position Y	Meters	d	8
36		FBR burst ref position Z	Meters	d	8
37		FBR burst reference latitude	Degrees	d	8
38		FBR burst reference longitude	Degrees	d	8
39		FBR burst reference Elevation	Meters	d	8
40		The record beam echo extracted from FBR		ss	2
41		Beam index (-32, +31)		ss	2
42		Beam angle with zero Doppler	rad	f	4
43		Beam angle with real antenna boresight	rad	f	4
44		Number of range bins from Tx to Rx centre of range window	Range bins	sl	4
45		Steer angle	rad	f	4

46		Roll angle	deg	f	4
47		Pitch angle	deg	f	4
48		Yaw angle	deg	f	4
49		Heading	deg	f	4
50		Doppler correction	m	f	
51		Coarse Doppler correction	Range bin	f	4
52		Fine Doppler correction	Range bin/ N_s	f	4
53		Slant range	m	f	4
Repeated N_c times within beam group					
54	$\Phi[N_{ex}]$	Complex beam echo samples over extended range window		f	$4*2*N_{ex}$

3.2.4. ASIRAS Level 1B Processed Data (ASI_SIN_1B & ASI_LAM_1B)

The following diagram provides an overview of the ASIRAS level 1b product. Each product consists of 2 elements.

1. An ASCII header, Table 3-14 to Table 3-17, which consists of a main product header (MPH), specific product header (SPH) and data set descriptors (DSDs). **In most cases parameters in the header are not filled by the ASIRAS processor since they have no meaning to the airborne case. Note that LAM and SAR modes are the same and HAM can only function as a SARIn mode.**
2. A binary (big endian byte ordered, [R1]) measurement data set (MDS) which is formatted depending on the mode of instrument operation (Table 3-18 to Table 3-21).

Figure 3-2 ASIRAS level 1b product header. Note that only one data set record is available for ASIRAS.

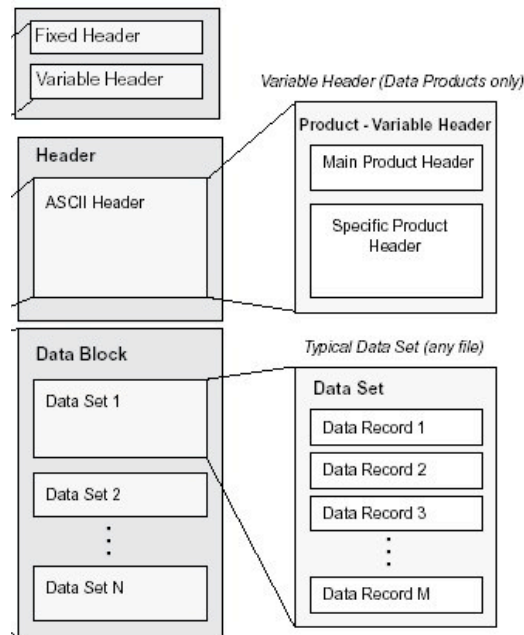

The ASIRAS level 1b data record is structured in a similar way to those defined for the CryoSat PDS. However there are a number of exceptions

- DSD DS names are unique to ASIRAS
- Additional parameters are added to the measurement group (OCOG/Threshold re-tracker and aircraft attitude parameters, for example).
- Geo-correction fields are all set to zero. Generation of these corrections is not implemented.
- Average pulse-width limited echo fields are all set to zero.
- Waveform group waveforms are of a length specific to ASIRAS and have no relation to those of the CryoSat level 1b products.

3.2.4.1. ASIRAS Level 1b MPH Description

The following table describes the ASIRAS level 1b MPH.

Table 3-14 ASIRAS MPH

Field #	Description	Units	Bytes	Format
<i>Product Identification Info</i>				
#01	PRODUCT=	keyword	8	
	quotation mark (")		1	uc
	Product File Name It is left justified with trailer blanks		62	See 3.1
	quotation mark (")		1	uc
	newline character	terminator	1	
#02	PROC_STAGE=	keyword	11	11*uc
	Processing stage code: N = Near-Real Time T = Test O = OFF Line (Systematic) R = Reprocessing		1	

	L = Long Term Archive			
	newline character	terminator	1	
#03	REF_DOC=	keyword	8	8*uc
	quotation mark (“)		1	uc
	Reference DFCB Document describing the product		23	23*uc
	quotation mark (“)		1	uc
	newline character	terminator	1	
#04	Spare (blank characters)		40	40*uc
	newline character	terminator	1	uc
<i>Data Processing Information</i>				
#05	ACQUISITION_STATION=	keyword	20	20*uc
	quotation mark (“)		1	uc
	Acquisition Station ID Filled by blanks		20	Kiruna
	quotation mark (“)		1	uc
	newline character	terminator	1	
#06	PROC_CENTER=	keyword	12	12*uc
	quotation mark (“)		1	uc
	Processing Center ID code		6	PDS
	quotation mark (“)		1	uc
	newline character	terminator	1	
#07	PROC_TIME=	keyword	10	10*uc
	quotation mark (“)		1	uc
	Processing Time (Product Generation Time)	UTC	27	dd-MMM-yyyy hh:mm:ss.uuuuuu
	quotation mark (“)		1	uc
	newline character	terminator	1	
#08	SOFTWARE_VER=	keyword	13	13*uc
	quotation mark (“)		1	uc
	Processor name, up to 8 characters, and software version number followed by trailer blanks if any. If not used set to blanks		14	14*uc ProcessorName/VV.rr
	quotation mark (“)		1	uc
	newline character	terminator	1	
#09	Spare (blank characters)		40	40*uc
	newline character	terminator	1	uc
<i>Information on Time of Data</i>				
#10	SENSING_START=	keyword	14	14*uc
	quotation mark (“)		1	uc
	UTC start time of data sensing. This is the UTC start time of the Input Level 0 Product. If not used set to 27 blanks	UTC	27	dd-MMM-yyyy hh:mm:ss.uuuuuu
	quotation mark (“)		1	uc
	newline character	terminator	1	
#11	SENSING_STOP=	keyword	13	13*uc
	quotation mark (“)		1	uc
	UTC stop time of data sensing. This is the UTC stop time of the Input Level 0 Product. If not used set to 27 blanks	UTC	27	dd-MMM-yyyy hh:mm:ss.uuuuuu
	quotation mark (“)		1	uc
	newline character	terminator	1	
#12	Spare (blank characters)		40	40*uc

	newline character	terminator	1	uc
<i>Orbit Information</i>				
#13	PHASE=	keyword	6	6*uc
	Phase Code: phase letter (A, B, ...) If not used set to X		1	
	newline character	terminator	1	uc
#14	CYCLE=	keyword	6	6*uc
	Cycle number. If not used set to +000		4	%+04d
	newline character	terminator	1	uc
#15	REL_ORBIT=	keyword	10	10*uc
	Relative Orbit Number at sensing start time. If not used set to +00000		6	%+06d
	newline character	terminator	1	uc
#16	ABS_ORBIT=	keyword	10	10*uc
	Absolute Orbit Number at sensing start time. If not used set to +00000		6	%+06d
	newline character	terminator	1	uc
#17	STATE_VECTOR_TIME=	keyword	18	18*uc
	quotation mark (")		1	uc
	UTC state vector time It is filled properly in case of usage of FOS Predicted Orbit information otherwise it shall be set to 27 blanks	UTC	27	dd-MMM-yyyy hh:mm:ss.uuuuuu
	quotation mark (")		1	uc
	newline character	terminator	1	
#18	DELTA_UTI=	keyword	10	10*uc
	Universal Time Correction: DUT1 = UT1 - UTC Not used for ASIRAS. It shall be set to +.000000	s	8	%+08.6f
	<s>	units	3	3*uc
	newline character	terminator	1	
#19	X_POSITION=	keyword	11	11*uc
	X position in Earth Fixed Reference. If not used set to +0000000.000	m	12	%+012.3f
	<m>	units	3	3*uc
	newline character	terminator	1	
#20	Y_POSITION=	keyword	11	11*uc
	Y position in Earth Fixed Reference. If not used set to +0000000.000	m	12	%+012.3f
	<m>	units	3	3*uc
	newline character	terminator	1	
#21	Z_POSITION=	keyword	11	11*uc
	Z position in Earth Fixed Reference. If not used set to +0000000.000	m	12	%+012.3f
	<m>	units	3	3*uc
	newline character	terminator	1	
#22	X_VELOCITY=	keyword	11	11*uc
	X velocity in Earth Fixed Reference. If not used set to +0000.000000	m/s	12	%+012.6f
	<m/s>	units	5	5*uc
	newline character	terminator	1	
#23	Y_VELOCITY=	keyword	11	11*uc
	Y velocity in Earth Fixed Reference.	m/s	12	%+012.6f



	If not used set to +0000.000000			
	<m/s>	units	5	5*uc
	newline character	terminator	1	
#24	Z_VELOCITY=	keyword	11	11*uc
	Z velocity in Earth Fixed Reference. If not used set to +0000.000000	m/s	12	%+012.6f
	<m/s>	units	5	5*uc
	newline character	terminator	1	
#25	VECTOR_SOURCE=	keyword	14	14*uc
	quotation mark (“)		1	uc
	Source of Orbit State Vector Record FP = FOS predicted DN = DORIS Level 0 navigator DP = DORIS precise orbit FR = FOS Restituted DI = DORIS Preliminary		2	2*uc
	quotation mark (“)		1	uc
	newline character	terminator	1	
#26	Spare (blank characters)		40	40*uc
	newline character	terminator	1	uc
<i>SBT to UTC conversion Information</i>				
#27	UTC_SBT_TIME=	keyword	13	13*uc
	quotation mark (“)		1	uc
	Not used and set to 27 blanks		27	\$
	quotation mark (“)		1	uc
	newline character	terminator	1	uc
#28	SAT_BINARY_TIME=	keyword	16	16*uc
	Satellite Binary Time Not used for Cryosat and it shall be set to zeros		11	+0000000000
	newline character	terminator	1	uc
#29	CLOCK_STEP =	keyword	11	11*uc
	Clock Step Not used for Cryosat and it shall be set to zeros		11	+0000000000
	<ps>	units	4	4*uc
	newline character	terminator	1	uc
#30	Spare (blank characters)		32	32*uc
	newline character	terminator	1	uc
<i>Leap Second Information</i>				
#31	LEAP.UTC=	keyword	9	9*uc
	quotation mark (“)		1	uc
	UTC Time of the occurrence of the leap second. If a leap second occurred in the product window the field is set by a devoted function in the CFI EXPLORER_ORBIT library (see [EXPL_ORB-SUM] for details), otherwise it is set to 27 blanks. It corresponds to the time after the Leap Second occurrence (i.e. midnight of the day after the leap second)		27	dd-MMM-yyyy hh:mm:ss.uuuuuu
	quotation mark (“)		1	uc
	newline character	terminator	1	uc

#32	LEAP_SIGN=	keyword	10	10*uc
	Leap second sign If a leap second occurred in the product window the field is set to the expected value by a devoted function in the CFI EXPLORER_ORBIT library (see [EXPL_ORB-SUM] for details), otherwise it is set to +000.	S	4	%+04d
	newline character	terminator	1	uc
#33	LEAP_ERR=	keyword	9	9*uc
	Leap second error flag. This field is always set to 0 considering that CRYOSAT products have true UTC times		1	uc
	newline character	terminator	1	uc
#34	Spare (blank characters)		40	40*uc
	newline character	terminator	1	uc
<i>Product Confidence Data Information</i>				
#35	PRODUCT_ERR=	keyword	12	12*uc
	Product Error Flag set to 1 if errors have been reported in the product		1	uc
	newline character	terminator	1	uc
<i>Product Size Information</i>				
#36	TOT_SIZE=	keyword	9	9*uc
	Total size of the product	bytes	21	%+021d
	<bytes>	units	7	7*uc
	newline character	terminator	1	Uc
#37	SPH_SIZE=	keyword	9	9*uc
	Length of the SPH	bytes	11	%+011d
	<bytes>	units	7	7*uc
	newline character	terminator	1	Uc
#38	NUM_DSD=	keyword	8	8*uc
	Number of Data Set Descriptors, including spares and all other types of DSDs		11	%+011d
	newline character	terminator	1	Uc
#39	DSD_SIZE=	keyword	9	9*uc
	Length of each DSD	bytes	11	%+011d
	<bytes>	units	7	7*uc
	newline character	terminator	1	Uc
#40	NUM_DATA_SETS=	keyword	14	14*uc
	Number of attached Data Sets (note that not all the DSDs have a DS attached)		11	%+011d
	newline character	terminator	1	Uc
#41	CRC=	keyword	4	4*uc
	Cyclic Redundancy Code computed as overall value of all records of the Measurement Data Set. If not computed it shall be set to -00001		6	%+06d
	newline character	terminator	1	Uc
#42	Spare (blank characters)		29	29*uc
	newline character	terminator	1	uc
	TOTAL		1247	

3.2.4.2.

ASIRAS Level 1b Specific Product Header (SPH)

The following section describes the ASIRAS level 1b SPH.

Table 3-15 ASIRAS SPH description

Field #	Description	Units	Bytes	Data Type
<i>Product description and identification</i>				
#1	SPH_DESCRIPTOR=	keyword	15	15*uc
	quotation mark (“)		1	uc
	ASCII string describing the product		28	28*uc ASI_SAR_1B SPECIFIC HEADER
	quotation mark (“)		1	uc
	newline character	terminator	1	uc
<i>Product Time information</i>				
#2	START_RECORD_TAI_TIME=	keyword	22	22*uc
	quotation mark (“)		1	uc
	TAI of the first record in the Main MDS of this product	TAI	27	dd-MMM-yyyy hh:mm:ss.uuuuuu
	quotation mark (“)		1	uc
	newline character	terminator	1	uc
#3	STOP_RECORD_TAI_TIME=	keyword	21	21*uc
	quotation mark (“)		1	uc
	TAI of the last record in in the Main MDS of this product	TAI	27	dd-MMM-yyyy hh:mm:ss.uuuuuu
	quotation mark (“)		1	uc
	newline character	terminator	1	uc
<i>Product Orbit Information</i>				
#4	ABS_ORBIT_START=	Keyword	16	16*uc
	Absolute Orbit Number at Product Start Time		6	%06d
	Newline character	terminator	1	uc
#5	REL_TIME_ASC_NODE_START=	Keyword	24	24*uc
	Relative time since crossing ascending node time relative to start time of data sensing	s	11	%011.6f
	<s>	units	3	3*uc
	Newline character	terminator	1	Uc
#6	ABS_ORBIT_STOP=	Keyword	15	15*uc
	Absolute Orbit Number at Product Stop Time		6	%06d
	Newline character	terminator	1	uc
#7	REL_TIME_ASC_NODE_STOP=	Keyword	23	23*uc
	Relative time since crossing ascending node time relative to stop time of data sensing	s	11	%011.6f
	<s>	units	3	3*uc
	Newline character	terminator	1	uc
#8	EQUATOR_CROSS_TIME.UTC=	Keyword	23	23*uc
	Quotation mark (“)		1	uc
	Time of Equator crossing at the ascending node of the sensing start time	UTC	27	dd-MMM-yyyy hh:mm:ss.uuuuuu
	Quotation mark (“)		1	uc

	Newline character	terminator	1	uc
#9	EQUATOR_CROSS_LONG=	Keyword	19	19*uc
	Longitude of Equator Crossing at the ascending node of the sensing start time (positive East, 0 = Greenwich) referred to WGS84	s	11	%+011d
	<10-6degE>	units	10	10*uc
	Newline character	terminator	1	uc
#10	ASCENDING_FLAG=	Keyword	15	15*uc
	Orbit Orientation at the sensing start time A= Ascending D= Descending		1	uc
	Newline character	terminator	1	uc
	<i>Product Location Information</i>			
#11	START_LAT=	keyword	10	10*uc
	WGS84 latitude of the first record in the Main MDS (positive north)	[10-6 deg]	11	%+011d
	<10-6degN>	units	10	10*uc
	newline character	terminator	1	uc
#12	START_LONG=	keyword	11	11*uc
	WGS84 longitude of the first record in the Main MDS (positive East, 0 = Greenwich)	[10-6 deg]	11	%+011d
	<10-6degE>	units	10	10*uc
	newline character	terminator	1	uc
#13	STOP_LAT=	keyword	9	9*uc
	WGS84 latitude of the last record in the Main MDS (positive north)	[10-6 deg]	11	%+011d
	<10-6degN>	units	10	10*uc
	newline character	terminator	1	uc
#14	STOP_LONG=	keyword	10	10*uc
	WGS84 longitude of the last record in the Main MDS (positive East, 0 = Greenwich)	[10-6 deg]	11	%+011d
	<10-6degE>	units	10	10*uc
	newline character	terminator	1	uc
#15	Spare (blank characters)	ascii	50	50*uc
	newline character	terminator	1	uc
<i>Level 0 Quality information</i>				
#16	L0_PROC_FLAG=	keyword	13	13*uc
	Processing errors significance flag (1 or 0). 1 if the percentage of SIRAL packets free of processing errors is less than the acceptable threshold		1	uc
	newline character	terminator	1	uc
	#17	L0_PROCESSING_QUALITY=	keyword	22
Percentage of quality checks successfully passed during the SP processing (max allowed +10000)		[10-2 %]	6	%+06d
<10-2%>		units	7	7*uc
newline character		terminator	1	uc
#18	L0_PROC_THRESH=	keyword	15	15*uc

	Minimum acceptable percentage of quality threshold that must be passed during SP processing (max allowed +10000)	[10-2 %]	6	%+06d
	<10-2%>	units	7	7*uc
#19	newline character	terminator	1	uc
	L0_GAPS_FLAG=	keyword	13	13*uc
	Gaps significance flag (1 or 0). 1 if gaps (either caused by extraction or alignment failures) were detected during the SP processing		1	uc
#20	newline character	terminator	1	uc
	L0_GAPS_NUM=	keyword	12	12*uc
	Number of gaps detected during the SP processing (no gaps indicated as +0000000)		8	%+08d
#21	newline character	terminator	1	uc
	Spare (blank characters)	ascii	50	50*uc
	newline character	terminator	1	uc
<i>ASIRAS Instrument Configuration</i>				
#22	ASI_OP_MODE=	keyword	12	12*uc
	quotation mark (“)		1	uc
	ASIRAS Operative Mode: HAM\$\$\$\$\$ LAM\$\$\$\$\$ (strings shorter than 10 are filled in with blanks \$)		10	10*uc
#23	quotation mark (“)		1	uc
	newline character	terminator	1	uc
	ASI_CONFIGURATION=	keyword	18	17*uc
	quotation mark (“)		1	uc
	SIRAL Configuration: RX_1\$\$\$ RX_2\$\$\$ BOTH\$\$\$ UNKNOWN (strings shorter than 7 are filled in with blanks)		7	7*uc
	quotation mark (“)		1	uc
	newline character	terminator	1	uc
<i>Surface Statistics</i>				
#24	OPEN_OCEAN_PERCENT=	Keyword	19	19*uc
	Percentage of records detected on open ocean or semi-enclosed seas	[10-2%]	6	%+06d
	<10-2%>	Units	7	7*uc
#25	newline character	Terminator	1	uc
	CLOSE_SEA_PERCENT=	Keyword	18	18*uc

#26	Percentage of records detected on closed seas or inland lakes	[10-2%]	6	%+06d
	<10-2%>	Units	7	7*uc
	Newline character	Terminator	1	uc
	CONTINENT_ICE_PERCENT=	Keyword	22	22*uc
	Percentage of records detected on continental ice	[10-2%]	6	%+06d
#27	<10-2%>	Units	7	7*uc
	Newline character	Terminator	1	uc
	LAND_PERCENT	Keyword	13	13*uc
	Percentage of records detected on land	[10-2%]	6	%+06d
	Percentage of records detected on land	[10-2%]	6	%+06d
#28	<10-2%>	Units	7	7*uc
	Newline character	Terminator	1	uc
	Spare (blank characters)	ascii	50	50*uc
	Newline character	Terminator	1	uc
	<i>Level 1 Processing information</i>			
#29	LIB_PROD_STATUS=	keyword	16	16*uc
	Complete/Incomplete Product Completion Flag (0 or 1). 1 if the Product as a duration shorter than the input Level 0		1	uc
	newline character	terminator	1	uc
#30	LIB_PROC_FLAG=	keyword	14	14*uc
	Processing errors significance flag (1 or 0). 1 if the percentage of DSR free of processing errors is less than the acceptable threshold		1	uc
	newline character	terminator	1	uc
#31	LIB_PROCESSING_QUALITY=	keyword	23	23*uc
	Percentage of quality checks successfully passed during Level 1B processing (max allowed +10000)	[10-2 %]	6	%+06d
	<10-2%>	units	7	7*uc
#32	newline character	terminator	1	uc
	LIB_PROC_THRESH=	keyword	16	16*uc
	Minimum acceptable percentage of quality threshold that must be passed during Level 1B processing (max allowed +10000)	[10-2 %]	6	%+06d
#33	<10-2%>	units	7	7*uc
	newline character	terminator	1	uc
	Spare (blank characters)	ascii	50	50*uc
	newline character	terminator	1	uc
TOTAL			1112	
<i>DSD Section</i>				

3.2.4.3.

ASIRAS Data Set Description

The DSD is described in the following table. The size of a DSD is 280 bytes. All fields are filled by the ASIRAS processor.

#N	DSD			
#N.1	DS_NAME=	keyword	8	8*uc
	quotation mark		1	uc
	Name describing the Data Set		28	28*uc
	quotation mark		1	uc
	newline character	terminator	1	uc
#N.2	DS_TYPE=	keyword	8	8*uc
	Type of Data Set. It can be: M = Measurement R = Reference		1	uc
	newline character	terminator	1	uc
<i>External product reference</i>				
#N.3	FILENAME=	keyword	9	9*uc
	quotation mark		1	uc
	Name of the Reference File. Used if DS_TYPE is set to R. It is left justified with trailer blanks. The file name includes the extension. If not used it is set to 62 blanks.		62	62*uc
	quotation mark		1	uc
	newline character	terminator	1	uc
<i>Position and size of DS</i>				
#N.4	DS_OFFSET=	keyword	10	10*uc
	Length in bytes of MPH + SPH (including DSDs) + DS size of previous Data Set (if any).	Byte	21	%+021d
	<bytes>	units	7	7*uc
	newline character	terminator	1	uc
#N.5	DS_SIZE=	keyword	8	8*uc
	Length in bytes of the attached Data Set Used if DS_TYPE is set to M If not used set to 0	byte	21	%+021d
	<bytes>	units	7	7*uc
	newline character	terminator	1	uc
<i>Number and length of DSRs</i>				
#N.6	NUM_DSR=	keyword	8	8*uc
	Number of Data Set Records		11	%+011d
	newline character	terminator	1	uc
#N.7	DSR_SIZE=	keyword	9	9*uc
	Length in bytes of the Data Set Record If not used set to +0 If variable set to -1	byte	11	%+011d
	<bytes>	units	7	7*uc
	newline character	terminator	1	uc
#N.8	Spare	ascii	32	32*uc
	newline character	terminator	1	uc

Table 2.3.2-2 Generic DSD Description

A variable number of DSDs will compose the SPH. Variability in fact depends most on the number of auxiliary files and input Level 0 files effectively used to generate the product.

For convenience Measurement DSDs (1 or more) should appear first in the list, followed by all the needed Reference DSDs.

The effective size of the SPH in number of bytes is defined in field #37 SPH_SIZE of the MPH (§3.2.4.1).

The total number of DSD Descriptors is defined in field #38 of the MPH (§3.2.4.1).

The number of Measurement DSDs is defined in field 40 of the MPH (§3.2.4.1).

For the Measurement Data Sets the DSD 1 (M) may have the following options for the DS_NAME:

Table 3-16 ASIRAS DS NAMES for L1b measurement products

<i>DS_NAME</i>	<i>Description</i>
ASI_L1B_SAR	ASIRAS SAR-LAM
ASI_L1B_SAR_A	ASIRAS-SAR-LAM-A
ASI_L1B_SAR_W	ASIRAS-SAR-LAM-W (LAM or LAM-A echoes windowed to 256 samples).
ASI_L1B_SARIN	ASIRAS SARIn-HAM

Table 3-17 ASIRAS DS NAMES for reference DSDs

<i>DS_NAME</i>	
ASI_CONSTANTS_FILE	Constants File
ASI_PROC_CONFIG_PARAMS_FILE	Processor Configuration Parameters File
DGPS_R_FILE	Rear DGPS
DGPS_F_FILE	Front DGPS
INS_FILE	INS attitude file
IPF_AS_DATABASE_FILE	Instrument characterization database
IPF_POSITIONS	Instrumentation locations described in AMR

3.2.5. ASIRAS Measurement Data Sets

The general record structure is shown in the following diagram

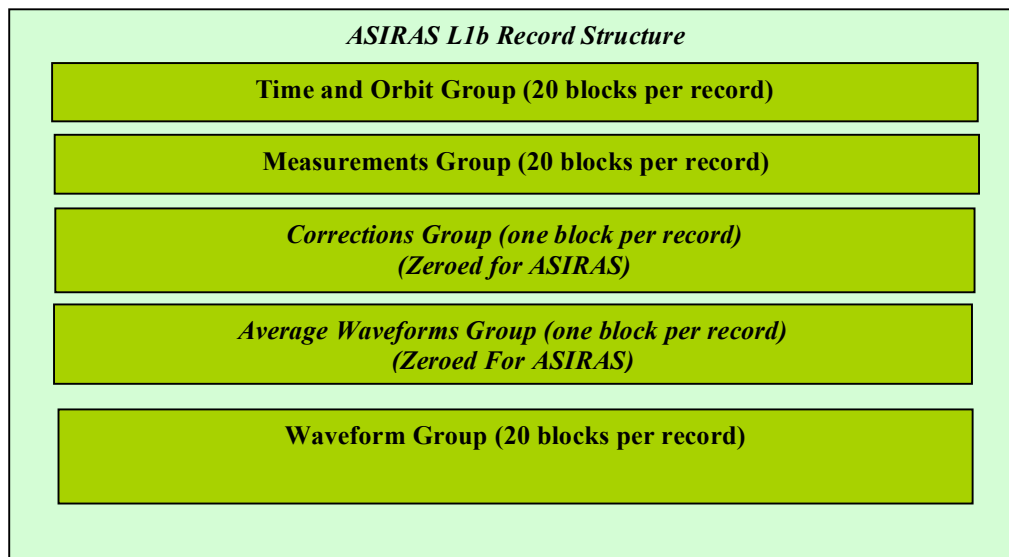

Figure 3-3 ASIRAS L1b record structure

3.2.5.1. ASI_SIN_L1B (ASIRAS High Altitude SARIn Mode Level 1b)

The ASIRAS SARIn (High altitude mode) binary big endian data record structure is provided in the following table.

Table 3-18 ASI_SIN_L1B record structure

Identifier	Description	Unit	Type	Size
Time & Orbit Group Repeated 20 times per record				Sub Total=84*20
1	Days (see note at the bottom of this table)	TAI	sl	4
2	Seconds		ul	4
3	Microseconds		ul	4
4	Spare		sl	4
5	Spare		us	2
6	Spare		us	2
7	Instrument Config	Table 3-22	ul	4
8	Burst Counter		ul	4
9	Geodetic latitude of ASIRAS centre of baseline	10 ⁻⁷ Deg	sl	4
10	Longitude of ASIRAS center of baseline	10 ⁻⁷ Deg	sl	4
11	WGS-84 ellipsoidal altitude of ASIRAS centre of baseline	10 ⁻³ m	sl	4
12	Altitude rate determined from DGPS	10 ⁻⁶ m/s	sl	4
13	Velocity [x,y,z], described in ITRF derived from ROC of DGPS locations	10 ⁻³ m/s	sl	3*4
14	Real antenna beam direction vector [x,y,z] described in CPRF	10 ⁻⁶ m	sl	3*4
15	Interferometer baseline [x,y,z] described in CPRF	10 ⁻⁶ m	sl	3*4
16	Measurement Confident data	Table 3-23	ul	4
Measurements group Repeated 20 times				Sub Total 94*20
17	Window delay	10 ⁻¹² s	sll	8
18	Spare	N/A	sl	4
19	OCOG width (see notes) USE WITH CAUTION	Range bins*100	sl	4
20	OCOG or Threshold ⁷ re-tracker derived range (see	10 ⁻³ m	sl	4

⁷ The threshold re-tracker is only used for diagnostic purposes and data delivered to CVRT is not re-tracked using this function.

Table 3-24 for re-tracker used) USE WITH CAUTION				
21	Surface elevation determined from field 20. USE WITH CAUTION	10^{-3} m	sl	4
22	AGC Channel 1	dB/100	sl	4
23	AGC Channel 2	dB/100	sl	4
24	Total fixed gain Ch1	dB/100	sl	4
25	Total fixed gain Ch2	dB/100	sl	4
26	Transmit Power	10^{-6} Watts	sl	4
27	Doppler range correction	10^{-3} m	sl	4
28	Instrument range correction Ch 1	10^{-3} m	sl	4
29	Instrument range correction Ch 2	10^{-3} m	sl	4
30	Spare		sl	4
31	Spare		sl	4
32	Internal phase correction	10^{-6} rad	sl	4
33	External phase correction	10^{-6} rad	sl	4
34	Noise power	dB/100	sl	4
35	Roll w.r.t NAR	10^{-3} Deg	ss	2
36	Pitch w.r.t NAR	10^{-3} Deg	ss	2
37	Yaw w.r.t NAR	10^{-3} Deg	ss	2
38	Spare	N/A	ss	2
39	Heading w.r.t local north	10^{-3} Deg	sl	4
40	Standard deviation of roll during stack integration	10^{-4} Deg	us	2
41	Standard deviation of pitch during stack integration	10^{-4} Deg	us	2
42	Standard deviation of yaw during stack integration	10^{-4} Deg	us	2
Corrections Group (once per record) Empty for ASIRAS				Sub Total 64
43	Spare		uc	64*1
Average pulse-width limited Waveform group (once per record) Empty for ASIRAS				Sub Total 556
44	Spare		uc	556*1
Multilooked Waveform Group (repeated 20 times per record)				Sub Total 2160*20
45	Multi-looked Power Echo.	Normalised (0-65535)	us	256*2
46	Linear scale factor, A		sl	4
47	Power of 2 scale factor,B		sl	4
48	Number of multilooked echoes		us	2
49	Flags	Table 3-24	us	2
50	Beam behaviour parameters[50]	Table 3-25	us	50*2
51	Coherence echo	10^{-3}	us	256*2
52	Phase difference echo	10^{-6} rad	sl	256*4
Total 47380				

Notes for ASI_SIN_L1B:

Fields 1: Referenced to TAI :The ephemeris in days of the the center of instrument baseline when it was located at the position provided by the latitude and longitude fields. The number of days is with respect to 1st Jan 2000.

Fields 2: Referenced to TAI: The integer number of seconds of the day of the the center of instrument baseline when it was located at the position provided by the latitude and longitude fields.

Fields 3: Referenced to TAI: The integer number of micro seconds of the the center of instrument baseline when it was located at the position provided by the latitude and longitude fields.

Field 11: The ASIRAS centre of baseline location is calculated by interpoating the 1Hz DGPS measures using an 8-point Lagrangian interpolator based on approximate locations of the GPS receivers in the aircraft mechanical reference frame. The procedure is described in §4.9.

Field 13: The aircraft velocity vector is described in the ITRF. It is generated from first differences of DGPS locations of either the front or rear GPS located on the aircraft.

Field 14: Real antenna boresight vector vector, $\hat{\mathbf{m}}_a$, is described in §4.11. The vector is converted to mm in the product. Note: it has not been corrected for the positioning error described in §4.12.

Field 15: Interferometer baseline vector, $\hat{\mathbf{m}}_b$, is described in §4.11. The vector is converted to mm in the product. The baseline vector is defined as the vector from a reference point on the transmit antenna (the right hand side antenna with respect to the positive aircraft x axis) to the receive antenna referente point. The reference points are at the physical centre of 2 patch antennae.

Field 17: is the time delay from chirp transmit to the centre of the range window (labelling range filters 0 to 255, the centre is range filter 128). To this time delay the smallest value of fields 28 and 29 is convered to a delay and added. The difference between field 28 and 29 is applied to waveform with the longer instrument path delay as a waveform shift during slant range correction (TBC).

Field 19: Data delivered to CVRT is processed with an OCOG tracker. The OCOG width (in units of range bin) is a parameter describing the spread in range of scatterer returns in the azimuth processed footprint.

Field 20: The re-tracked range is an aproximate range from the aircraft reference frame origin to the scattering surface. The re-tracker used for this purpose is the Offset Centre of Gravity (OCOG) re-tracker or threshold re-tracker not designed specifically for the ASIRAS waveforms (see Table 3-24 to determine which re-tracker has been used). Caution should be taken when utilising power waveforms processed with the OCOG re-tracker since it is not designed to obtain the leading edge of waveforms expect from azimuth processed waveforms. Data delivered to CVRT will contain data processed with the OCOG re-tracker only.

Field 21: This approximate surface elevation measure uses the re-tracked range from field 20, and removes that from the aircraft reference frame origin measure in field 11. The elevation measurement assumes that the echoing point is nadir to the aircraft (on the so called ground track) which in general is not the case. Hence interferometric phase difference information is not used in the generation of this parameter. As described in field 20, the OCOG re-tracker results should be used with caution.

Field 28: Total instrument and antenna cable group delay converted to a range correction for receive chain 1 such that the echo reference can be related to the antenna reference point.

Field 29: Total instrument and antenna cable group delay converted to a range correction for receive chain 2 such that the echo reference can be related to the antenna reference point.

Calculation of range specific to HAM:

Re-tracked range, R_{rr_ham} , is provided by the following equation:

$$R_{rr_ham} = \frac{c}{2} \left\{ T_w + \frac{T_{uc} F_s}{BN_{FFT_ham}} \left(n - \frac{N_{FFT_ham}}{2} \right) \right\} \quad \text{meters} \quad \text{Equation 3.2-1}$$

Where, T_w is the window delay taken from ASIRAS log file (of field 17), $T_{uc} = 4 \mu\text{S}$, is the uncompressed pulse

length (IST_PUL from Table 3-22), $B=1$ GHz, is the bandwidth, $F_s = 37.5$ MHz, the instrument sampling frequency, $N_{FFT_ham} = 256$ are the number of echo samples and $c = 299792458$ m/s. Echo samples are ordered between 0 and $N_{FFT_ham} - 1$. The centre of the range window is given by sample $N_{FFT_ham} / 2$.

For example using the raw ASIRAS data log file for profile A040914_03 the window delay for pulse, say, 643409, can be found by examination of the ASIRAS log file.

0000000047-17:45:15-14.09.2004: PRT Counter: 80425 RelTime [s]: 160.869 PRT Value [μ s]: 8.2667 relates to pulse $80425 * 8 = 643400^8$ and has a value of $8.2667 = T$ micro seconds.

If the re-tracker returns $n=100$ as the re-tracked echo then the one-way range

$$R_{rr_lam} = \frac{299792458}{2} \left\{ 8.2667 * 10^{-6} + \frac{4 * 10^{-6} * 37.5 * 10^6}{10^9 * 256} \left(100 - \frac{256}{2} \right) \right\} = 1236.688 \text{ meters.}$$

Note: If one wants to obtain the retracked range bin location from the re-tracked range then:

$$n = \frac{BN_{FFT_ham}}{T_{uc} F_s} \left(\frac{2R_{rr_ham}}{c} - T_w \right) + \frac{N_{FFT_ham}}{2} \quad \text{Equation 3.2-1}$$

Field 24 & 25: Extracted from ASIRAS IPF database.

Field 27: The Doppler range correction is computed by:

$$R_D = - \frac{T_s c V_{vert}}{\lambda B}, \text{ where, } T_s = 4 \mu S \text{ is the uncompressed pulse length (IST_PUL from Table 3-22),}$$

$c = 299792458$ m/s is the speed of Light in a vacuum, $B=1$ GHz is the instrument bandwidth, $\lambda = 0.022$ m is the carrier wavelength, V_{vert} is the altitude rate with respect to the referente ellipsoid. Note that level 1b data is corrected for effects of Doppler, however, due to the nature of the processor, this equation is not used at all within this process and is added here for compatilby with the CryoSat level 1b product.

Field 32 & 33: Extracted from ASIRAS IPF database.

Field 43: Geocorrections are not placed in the ASIRAS level 1b file structure and are set to zero.

Field 44: Average pulse-width limited power echoes are not calculated in the level 1b processor and all fields are set to zero.

Fields 45,51,52: Echo sample resolution, ΔR_{ham} , is calculated by the following equation:

$$\Delta R_{ham} = \frac{T_{uc} F_s c}{2BN_{FFT_ham}} \cdot \text{meters} \quad \text{Equation 3.2-2}$$

For ASIRAS high altitude mode (SARIn), $T_{uc} = 4 \mu S$ is the uncompressed pulse length (IST_PUL from Table 3-22), $F_s = 37.5$ MHz is the instrument sampling frequency, $c = 299792458$ m/s is the speed of Light in a vacuum, $B = 1$ GHz is the instrument bandwidth and $N_{FFT_ham} = 256$ samples.

This gives a resolution of $\Delta R_{ham} = 0.08783$ meters . Thus the range window length is given by

$$\Delta R_{w_ham} = N_{FFT_ham} \Delta R_{ham} = 22.485 \text{ meters.}$$

⁸ ASIRAS data acquired prior to the beginning 2005 logs instrument changes with respect to an echo count factor 8. Following the beginning 2005 the exact echo number is logged.

Fields 46 & 47: Power echoes have been scaled between counts of 0 and 65535. In order to scale the waveforms relative to each other (i.e., remove the effect of receiver gains and attenuations) the following formula needs to be applied to each echo:

A =linear power multiplier (field 39)

B =power of 2 multiplier (field 40)

$P[0, N_s - 1]$ = power echo array (field 38) of N_s samples

$P_s[0, N_s - 1]$ = scaled power echo array of N_s samples

$\forall n \in [0, N_s - 1]$

$$P_s[n] = 1 \times 10^{-9} 2^B AP[n]$$

Equation 3.2-3

Note: Variable AGC is compensated for in the processor based on ideal AGC values (not calibrated). Static instrument gain is estimated based on platform dependent antenna cable losses and instrument description, [R12].

Field 52 Interferometric phase difference convention. This can be reversed using the parameter <Reverse_Phase_Diff> in the processor configuration file §3.2.9.

3.2.5.2. ASI_LAM_L1B, ASI_LAMAL1B and ASI_LAM_W_L1B (ASIRAS SAR Level 1b)

The ASIRAS LAM-SAR record structure is similar to that of the high altitude SARIn mode with the exception that interferometric phase difference and coherence fields are not provided.

The original low altitude LAM mode contains waveforms processed with 4096 samples this is known as ASI_LAM_L1B (ASILL1B) **and will become obsolete following 2009 re-processing**. See Table 3-19.

The low sample rate low altitude LAM-A mode contains waveforms processed with 1024 samples this is known as ASI_LAM_A_L1B (ASIAL1B) **and will become obsolete following 2009 re-processing**. See Table 3-20.

Since both the described cases contain many samples with minimal information (noise floor) all processed data from 2009 will contain 256 samples. This will include a re-processing of all pre-2009 campaigns. This is known as ASI_LAM-W-L1B (ASIWL1B). See Table 3-21.

Table 3-19 ASI_LAM_L1B (ASILL1B) record format. This format will become obsolete for and following 2009 re-processing (See Table 3-21)

Identifier	Description	Unit	Type	Size
Time & Orbit Group Repeated 20 times per record				Sub Total=84*20
1	Days (see note at the bottom of this table)	TAI	sl	4
2	Seconds		ul	4
3	Microseconds		ul	4
4	Spare		sl	4
5	Spare		us	2
6	Spare		us	2
7	Instrument Configuration	Table 3-22	ul	4
8	Burst Counter		ul	4

9	Geodetic latitude of ASIRAS centre of baseline	10^{-7} Deg	sl	4
10	Longitude of ASIRAS centre of baseline	10^{-7} Deg	sl	4
11	WGS-84 ellipsoidal altitude of ASIRAS baseline centre	10^{-3} m	sl	4
12	Altitude rate determined from DGPS	10^{-6} m/s	sl	4
13	Velocity [x,y,z], described in ITRF derived from ROC of DGPS locations	10^{-3} m/s	sl	3*4
14	Real antenna beam direction vector [x,y,z] defined in CPRF	10^{-6} m	sl	3*4
15	Interferometer baseline [x,y,z]	10^{-6} m	sl	3*4
16	Measurement Confident data	Table 3-23	ul	4
Measurements group Repeated 20 times				Sub Total 94*20
17	Window delay	10^{-12} s	sll	8
18	Spare		sl	4
19	OCO width. USE WITH CAUTION	Range bins*100	sl	4
20	OCO or threshold ⁹ re-tracker range (see Table 3-24). USE WITH CAUTION	10^{-3} m	sl	4
21	Surface elevation derived from field 20. USE WITH CAUTION	10^{-3} m	sl	4
22	AGC Channel 1	dB/100	sl	4
23	AGC Channel 2	dB/100	sl	4
24	Total fixed gain Ch1	dB/100	sl	4
25	Total fixed gain Ch2	dB/100	sl	4
26	Transmit Power	10^{-6} Watts	sl	4
27	Doppler range correction	10^{-3} m	sl	4
28	Instrument range correction Ch 1	10^{-3} m	sl	4
29	Instrument range correction Ch 2	10^{-3} m	sl	4
30	Spare		sl	4
31	Spare		sl	4
32	Internal phase correction	10^{-6} rad	sl	4
33	External phase correction	10^{-6} rad	sl	4
34	Noise power	dB/100	sl	4
35	Roll w.r.t NAR	10^{-3} Deg	ss	2
36	Pitch w.r.t NAR	10^{-3} Deg	ss	2
37	Yaw w.r.t NAR	10^{-3} Deg	ss	2
38	Spare	N/A	ss	2
39	Heading w.r.t local north	10^{-3} Deg	sl	4
40	Standard deviation of roll	10^{-4} Deg	us	2

⁹ The threshold re-tracker is only used for diagnostic purposes. Data delivered to CVRT is not re-tracked using this function.

	during stack integration			
41	Standard deviation of pitch during stack integration	10^{-4} Deg	us	2
42	Standard deviation of yaw during stack integration	10^{-4} Deg	us	2
Corrections Group (once per record) Empty for ASIRAS				Sub Total 64
43	Spare		uc	64*1
Average pulse-width limited Waveform group (once per record) Empty for ASIRAS				Sub Total 8236
44	Spare		uc	8236*1
Multilooked Waveform Group (repeated 20 times)				Sub Total 8304*20
45	Multi-looked Power Echo.	Counts (0-65535)	us	4096*2
46	Linear scale factor, A		sl	4
47	Power of 2 scale factor,B		sl	4
48	Number of multilooked echoes		us	2
49	Flags	Table 3-24	us	2
50	Beam behaviour parameters[50]	Table 3-25	us	50*2
				Total 177940

Table 3-20 LAM-A-SAR (ASIAL1B) (Not used in re-processing : See Table 3-21)

Identifier	Description	Unit	Type	Size
Time & Orbit Group Repeated 20 times per record				Sub Total=84*20
1	Days (see note at the bottom of this table)	TAI	sl	4
2	Seconds		ul	4
3	Microseconds		ul	4
4	Spare		sl	4
5	Spare		us	2
6	Spare		us	2
7	Instrument Config	Table 3-22	ul	4
8	Burst Counter		ul	4
9	Geodetic latitude of ASIRAS centre of baseline	10^{-7} Deg	sl	4
10	Longitude of ASIRAS centre of baseline	10^{-7} Deg	sl	4
11	WGS-84 ellipsoidal altitude of ASIRAS baseline centre	10^{-3} m	sl	4
12	Altitude rate determined from DGPS	10^{-6} m/s	sl	4
13	Velocity [x,y,z], described in ITRF derived from ROC of DGPS locations	10^{-3} m/s	sl	3*4
14	Real antenna beam direction vector [x,y,z] defined in CPRF	10^{-6} m	sl	3*4
15	Interferometer baseline [x,y,z]	10^{-6} m	sl	3*4
16	Measurement Confident	Table 3-23	ul	4

		data		
Measurements group Repeated 20 times per record				Sub Total 94*20
17	Window delay	10^{-12} s	sll	8
18	Spare		sl	4
19	OCOg width. USE WITH CAUTION	Range bins*100	sl	4
20	OCOg or threshold ¹⁰ re- tracker range (see Table 3-24). USE WITH CAUTION	10^{-3} m	sl	4
21	Surface elevation derived from field 20. USE WITH CAUTION	10^{-3} m	sl	4
22	AGC Channel 1	dB/100	sl	4
23	AGC Channel 2	dB/100	sl	4
24	Total fixed gain Ch1	dB/100	sl	4
25	Total fixed gain Ch2	dB/100	sl	4
26	Transmit Power	10^{-6} Watts	sl	4
27	Doppler range correction	10^{-3} m	sl	4
28	Instrument range correction Ch 1	10^{-3} m	sl	4
29	Instrument range correction Ch 2	10^{-3} m	sl	4
30	Spare		sl	4
31	Spare		sl	4
32	Internal phase correction	10^{-6} rad	sl	4
33	External phase correction	10^{-6} rad	sl	4
34	Noise power	dB/100	sl	4
35	Roll w.r.t NAR	10^{-3} Deg	ss	2
36	Pitch w.r.t NAR	10^{-3} Deg	ss	2
37	Yaw w.r.t NAR	10^{-3} Deg	ss	2
38	Spare	N/A	ss	2
39	Heading w.r.t local north	10^{-3} Deg	sl	4
40	Standard deviation of roll during stack integration	10^{-4} Deg	us	2
41	Standard deviation of pitch during stack integration	10^{-4} Deg	us	2
42	Standard deviation of yaw during stack integration	10^{-4} Deg	us	2
Corrections Group (once per record) Empty for ASIRAS				Sub Total 64
43	Spare		uc	64*1
Average pulse-width limited Waveform group (once per record) Empty for ASIRAS				Sub Total 2092
44	Spare		uc	2092*1
Multilooked Waveform Group (repeated 20 times per record)				Sub Total 2160*20
45	Multi-looked Power Echo.	Counts (0-65535)	us	1024*2
46	Linear scale factor, A		sl	4
47	Power of 2 scale factor,B		sl	4

¹⁰ The threshold re-tracker is only used for diagnostic purposes. Data delivered to CVRT is not re-tracked using this function.

48	Number of multilooked echoes		us	2
49	Flags	Table 3-24	us	2
50	Beam behaviour parameters[50]	Table 3-25	us	50*2
Total 48916				

Table 3-21 ASI_LAM_W_L1B (ASIWL1B) Used for 2009 re-processing and all subsequent campaigns)

Identifier	Description	Unit	Type	Size
Time & Orbit Group Repeated 20 times per record				Sub Total=84*20
1	Days (see note at the bottom of this table)	TAI	sl	4
2	Seconds		ul	4
3	Microseconds		ul	4
4	Spare		sl	4
5	Spare		us	2
6	Spare		us	2
7	Instrument Config	Table 3-22	ul	4
8	Burst Counter		ul	4
9	Geodetic latitude of ASIRAS centre of baseline	10^{-7} Deg	sl	4
10	Longitude of ASIRAS centre of baseline	10^{-7} Deg	sl	4
11	WGS-84 ellipsoidal altitude of ASIRAS baseline centre	10^{-3} m	sl	4
12	Altitude rate determined from DGPS	10^{-6} m/s	sl	4
13	Velocity [x,y,z], described in ITRF derived from ROC of DGPS locations	10^{-3} m/s	sl	3*4
14	Real antenna beam direction vector [x,y,z] defined in CPRF	10^{-6} m	sl	3*4
15	Interferometer baseline [x,y,z]	10^{-6} m	sl	3*4
16	Measurement Confident data	Table 3-23	ul	4
Measurements group Repeated 20 times per record				Sub Total 94*20
17	Window delay	10^{-12} s	sll	8
18	Spare		sl	4
19	OCO width. USE WITH CAUTION	Range bins*100	sl	4
20	OCO or threshold ¹¹ re-tracker range (see Table 3-24). USE WITH CAUTION	10^{-3} m	sl	4
21	Surface elevation derived from field 20.	10^{-3} m	sl	4

¹¹ The threshold re-tracker is only used for diagnostic purposes. Data delivered to CVRT is not re-tracked using this function.



USE WITH CAUTION				
22	AGC Channel 1	dB/100	sl	4
23	AGC Channel 2	dB/100	sl	4
24	Total fixed gain Ch1	dB/100	sl	4
25	Total fixed gain Ch2	dB/100	sl	4
26	Transmit Power	10 ⁻⁶ Watts	sl	4
27	Doppler range correction	10 ⁻³ m	sl	4
28	Instrument range correction Ch 1	10 ⁻³ m	sl	4
29	Instrument range correction Ch 2	10 ⁻³ m	sl	4
30	Spare		sl	4
31	Spare		sl	4
32	Internal phase correction	10 ⁻⁶ rad	sl	4
33	External phase correction	10 ⁻⁶ rad	sl	4
34	Noise power	dB/100	sl	4
35	Roll w.r.t NAR	10 ⁻³ Deg	ss	2
36	Pitch w.r.t NAR	10 ⁻³ Deg	ss	2
37	Yaw w.r.t NAR	10 ⁻³ Deg	ss	2
38	Spare	N/A	ss	2
39	Heading w.r.t local north	10 ⁻³ Deg	sl	4
40	Standard deviation of roll during stack integration	10 ⁻⁴ Deg	us	2
41	Standard deviation of pitch during stack integration	10 ⁻⁴ Deg	us	2
42	Standard deviation of yaw during stack integration	10 ⁻⁴ Deg	us	2
Corrections Group (once per record) Empty for ASIRAS				Sub Total 64
43	Spare		uc	64*1
Average pulse-width limited Waveform group (once per record) Empty for ASIRAS				Sub Total 556
44	Spare		uc	2092*1
Multilooked Waveform Group (repeated 20 times)				Sub Total 622*20
45	Multi-looked Power Echo.	Counts (0-65535)	us	256*2
46	Linear scale factor, A		sl	4
47	Power of 2 scale factor,B		sl	4
48	Number of multilooked echoes		us	2
49	Flags	Table 3-24	us	2
50	Beam behaviour parameters[50]	Table 3-25	us	50*2
Total 16620				

Notes for ASI_LAM_L1B, ASI_LAM_A_L1B and ASI_LAM_W_L1B:

Fields 1: Referenced to TAI :The ephemeris in days the ASIRAS centre of baseline was at the location provided by the latitude and longitude fields. The number of days is with respect to 1st Jan 2000.

Fields 2: Referenced to TAI: The integer number of seconds of the day the ASIRAS centre of baseline was at the location provided by the latitude and longitude fields.

Fields 3: Referenced to TAI: The integer number of micro seconds the ASIRAS centre of baseline was at the location provided by the latitude and longitude fields.

Field 11: The ASIRAS centre of baseline elevation is calculated by interpolating the 1Hz DGPS measures using an 8-point Lagrangian interpolator and a correction is then applied based on an approximate knowledge of the GPS receiver position within the aircraft mechanical reference frame described in §4.9.

Field 13: The aircraft velocity vector is described in the ITRF. It is generated from first differences of DGSP locations of either the front or rear GPS located on the aircraft (see §4.3).

Field 14: Real antenna boresight vector vector, $\hat{\mathbf{m}}_a$, is described in §4.11. The vector is converted to mm in the product. Note it has not been corrected for the positioning error described in §4.12.

Field 15: Interferometer baseline vector, $\hat{\mathbf{m}}_b$, is described in §4.11. The vector is converted to mm in the product. The baseline vector is defined as the vector from a reference point on the transmit antenna (the right hand side antenna with respect to the positive aircraft x axis) to the receive antenna referente point. The reference points are at the physical centre of 2 patch antennae.

Field 17: is the time delay from chirp transmit to the centre of the range window (labelling range bins 0 to 255, the centre is range bin 128). To this time delay the delay derived from field 29 is added.

Field 19: Data delivered to CVRT is processed with an OCOG tracker. The OCOG width (in units of range bin) is a parameter describing the spread in range of scatterer returns in the azimuth processed footprint.

Field 20: The re-tracked range is an approximate range from the aircraft reference frame origin to the scattering surface. The re-tracker used for this purpose is the Offset Centre of Gravity (OCOG) re-tracker or threshold re-tracker not designed specifically for the ASIRAS waveforms (see Table 3-24 to determine which re-tracker has been used). See field 21 for discusión on re-tracked range. Caution should be taken when utilising power waveforms processed with the OCOG re-tracker since it is not designed to obtain the leading edge of waveforms expect from azimuth processed waveforms. Data delivered to CVRT will contain data processed with the OCOG re-tracker only.

Field 21: This approximate surface elevation measure uses the re-tracked range from field 20, and removes that from the aircraft reference frame origin measure in field 11. The elevation measurement assumes that the echoing point is nadir to the aircraft (on the so called ground track) which in general is not the case. Hence interferometric phase difference information is not used in the generation of this parameter. As described in field 20, the OCOG re-tracker should be used with caution.

Field 28: Total instrument and antenna cable group delay converted to a range correction for receive chain 1 such that the echo reference can be related to the antenna reference point.

Field 29: Total instrument and antenna cable group delay converted to a range correction for receive chain 2 such that the echo reference can be related to the antenna reference point.

Calculation of range for LAM (LAM-A described after LAM):

Re-tracked range, R_{rr_lam} , is provided by the following equation:

$$R_{rr_lam} = \frac{cT_{uc}}{2B} \left\{ F_{lam_off} + \frac{F_{s_lam}}{N_{FFT_lam}} (n - N_{FFT_lam} / 2) \right\} \text{ meters} \quad \text{Equation 3.2-4}$$

where, F_{lam_off} , is the LAM frequency offset¹² (taking 20, 40, 60, 80, 100 or 120 MHz obtained from ASIRAS log file or IST_FRQ from Table 3-22), $T_{uc} = 80 \mu\text{S}$ (IST_PUL from Table 3-22), is the uncompressed pulse length, $B=1 \text{ GHz}$, is the bandwidth, $F_{s_lam} = 37.5 \text{ MHz}$, the instrument sampling frequency, $N_{FFT_lam} = 4096$ are the

¹² Only the initial LAM frequency offset obtained from the ASIRAS log file can be used for processing. Operationally ASIRAS may take other values during acquisition of a profile though this data can not be processed unless acquisition is at the nominal frequency offset.

number of echo samples and $c = 299792458$ m/s. Echo samples are ordered between 0 and $N_{FFT_lam} - 1$. The centre of the range window is given by sample $N_{FFT_lam} / 2$.

For example using ASIRAS log for profile A060426_03 the initial frequency offset is $F=20$ MHz

0000000019-20:42:30-26.04.2006: RelTime [s]: 0.003 Initial F306 [MHz]:20 Initial F320 [MHz]:0

and the re-tracker returns $n=2800$ as the re-tracked echo then the one-way range

$$R_{rr_lam} = \frac{299792458 * 80 * 10^{-6}}{2 * 1 * 10^9} \left\{ 20 * 10^6 + \frac{37.5 * 10^6}{4096} \left(2800 - \frac{4096}{2} \right) \right\} = 322.393 \text{ metres}$$

If one wants to compute the re-track range bin from the re-tracked range then use the following equation

$$n = \frac{N_{FFT_lam}}{F_s} \left(\frac{2BR_{rr_lam}}{cT_{uc}} - F_{lam_off} \right) + \frac{N_{FFT_lam}}{2} \quad \text{Equation 3.2-5}$$

Calculation of range for LAM-A:

Re-tracked range, R_{rr_lama} , is provided by the following equation:

$$R_{rr_lama} = \frac{cT_{uc}}{2B} \left\{ F_{lam_off} + \frac{F_{s_lama}}{N_{FFT_lama}} \left(n - N_{FFT_lama} / 2 \right) \right\} \quad \text{meters} \quad \text{Equation 3.2-6}$$

where, F_{lam_off} , is the initial LAM frequency offset (in steps of 5MHz obtained from ASIRAS log file), $T_{uc} = 80$ μ s, is the uncompressed pulse length, $B=1$ GHz, is the bandwidth, $F_{s_lama} = 9.375$ MHz, the instrument sampling frequency, $N_{FFT_lama} = 1024$ are the number of echo samples and $c = 299792458$ m/s. Echo samples are ordered between 0 and $N_{FFT_lama} - 1$. The centre of the range window is given by sample $N_{FFT_lama} / 2$

For example using ASIRAS LAM-A log for profile A070416_07 the initial frequency offset is $F=40$ MHz

0000000020-13:59:53-16.04.2007: RelTime [s]: 0.003 Initial F306 [MHz]:40 Initial F320 [MHz]:0

and the re-tracker returns $n=100$ as the re-tracked echo then the one-way range

$$R_{rr_lama} = \frac{299792458 * 80 * 10^{-6}}{2 * 1 * 10^9} \left\{ 40 * 10^6 + \frac{9.375 * 10^6}{1024} \left(100 - \frac{1024}{2} \right) \right\} = 434.435 \text{ meters}$$

If one wants to compute the re-track range bin from the re-tracked range then use the following equation

$$n = \frac{N_{FFT_lama}}{F_s} \left(\frac{2BR_{rr_lama}}{cT_{uc}} - F_{lam_off} \right) + \frac{N_{FFT_lama}}{2} \quad \text{Equation 3.2-7}$$

Field 24 & 25: Extracted from ASIRAS processor database.

Field 27: The Doppler range correction is computed by:

$$R_D = - \frac{T_s c V_{vert}}{\lambda B}, \quad \text{Equation 3.2-8}$$

where, $T_s = 80 \mu$ s is the uncompressed pulse length, $c = 299792458$ m/s is the speed of Light in a vacuum, $B=1$ GHz is the instrument bandwidth, $\lambda = 0.022$ m is the carrier wavelength, V_{vert} is the altitude rate with respect to the reference ellipsoid. Note that level 1b data is corrected for effects of Doppler, however, due to the nature of the processor, this equation is not used at all within this process and is added here for compatibility with the CryoSat level 1b product.

Field 32 & 33: Extracted from ASIRAS processor database (§6.2).

Field 43: Geocorrections are not placed in the ASIRAS level 1b file structure and are set to zero.

Field 44: Average pulse-width limited power echoes are not calculated in the level 1b processor and all fields are set to zero.

Fields 45: Echo sample resolution, ΔR_{lam} and ΔR_{lama} , for LAM and LAM-A are identical though formed from differing parameters,

LAM calculation:

ΔR_{lam} is calculated by the following equation.

$$\Delta R_{lam} = \frac{T_{uc} F_{s_lam} c}{2BN_{FFT_lam}} \quad \text{Equation 3.2-9}$$

For ASIRAS low altitude mode (LAM-SAR), $T_{uc}=80\mu s$ is the uncompressed pulse length, $F_{s_lam}=37.5\text{MHz}$ is the instrument sampling frequency, $c = 299792458\text{m/s}$ is the speed of Light in a vacuum, $B=1\text{GHz}$ is the instrument bandwidth and $N_{FFT_lam} = 4096$.

This gives a LAM-SAR resolution of $\Delta R_{lam} = 0.109787$ meters .

The range window length is given by $\Delta R_{w_lam} = N_{FFT_lam} \Delta R_{lam} = 449.867552$ meters

LAM-A calculation:

ΔR_{lama} is calculated by the following equation.

$$\Delta R_{lama} = \frac{T_{uc} F_{s_lama} c}{2BN_{FFT_lama}} \quad \text{Equation 3.2-10}$$

For ASIRAS low altitude mode (LAM-A-SAR), $T_{uc}=80\mu s$ is the uncompressed pulse length (IST_PUL in Table 3-22), $F_{s_lama}=9.375\text{MHz}$ (one fourth of F_{s_lam}) is the instrument sampling frequency, $c = 299792458\text{m/s}$ is the speed of Light in a vacuum, $B=1\text{GHz}$ is the instrument bandwidth and $N_{FFT_lama} = 1024$.

This gives a LAM-A-SAR resolution of $\Delta R_{lama} = 0.109787$ meters .

The range window length is given by $\Delta R_{w_lama} = N_{FFT_lama} \Delta R_{lama} = 112.467$ meters.

Fields 46 & 47: Power echoes have been scaled between counts of 0 and 65535. In order to scale the waveforms relative to each other (i.e., remove the effect of receiver gains and attenuations) the following formula needs to be applied to each echo:

A =linear power multiplier (field 45)

B =power of 2 multiplier (field 46)

$P[0, N_s - 1]$ = power echo array (field 44) of N_s samples

$P_s[0, N_s - 1]$ = scaled power echo array of N_s samples

$\forall n \in [0, N_s - 1]$

$$P_s[n] = 1 \times 10^{-9} 2^B AP[n] \quad \text{Equation 3.2-11}$$

Note: Variable AGC is compensated for in the processor based on ideal AGC values (not calibrated). Static instrument gain is estimated based on platform dependent antenna cable losses and instrument description, [R12].

Table 3-22 Instrument Configuration Flags

Bit Number	Label	Description
------------	-------	-------------

0-1	IST_MOD	Instrument mode 0 – SARin 1 – LAM 2 – LAM-A (Low sample rate) 3 - SARIn enhanced																																																														
2-5	IST_PUL	Pulse length: 0 4 micro sec 1 5 micro sec 2 20 micro sec 3 25 micro sec 4 30 micro sec 5 35 micro sec 6 40 micro sec 7 45 micro sec 8 80 micro sec 9-15 not used																																																														
6	IST_SID	Deleted																																																														
7-8	IST_RXC	Receive channel 0 – Rx 1 & 2 (SARin mode) 1 – Rx 1 (LAM) 2 – N/A																																																														
9-13	IST_FRQ	LAM mode freq offset: Note: In HAM this parameter is set to 63 (N/A). <table border="1" data-bbox="603 1048 1043 2029"> <thead> <tr> <th>Value</th> <th>Frequency</th> </tr> </thead> <tbody> <tr><td>0</td><td>0 MHz</td></tr> <tr><td>1</td><td>5</td></tr> <tr><td>2</td><td>10</td></tr> <tr><td>3</td><td>15</td></tr> <tr><td>4</td><td>20</td></tr> <tr><td>5</td><td>25</td></tr> <tr><td>6</td><td>30</td></tr> <tr><td>7</td><td>35</td></tr> <tr><td>8</td><td>40</td></tr> <tr><td>9</td><td>45</td></tr> <tr><td>10</td><td>50</td></tr> <tr><td>11</td><td>55</td></tr> <tr><td>12</td><td>60</td></tr> <tr><td>13</td><td>65</td></tr> <tr><td>14</td><td>70</td></tr> <tr><td>15</td><td>75</td></tr> <tr><td>16</td><td>80</td></tr> <tr><td>17</td><td>85</td></tr> <tr><td>18</td><td>90</td></tr> <tr><td>19</td><td>95</td></tr> <tr><td>20</td><td>100</td></tr> <tr><td>21</td><td>105</td></tr> <tr><td>22</td><td>110</td></tr> <tr><td>23</td><td>115</td></tr> <tr><td>24</td><td>120</td></tr> <tr><td>25</td><td>125</td></tr> <tr><td>26</td><td>130</td></tr> <tr><td>27</td><td>135</td></tr> <tr><td>28</td><td>140</td></tr> <tr><td>29-62</td><td>Not used</td></tr> </tbody> </table>	Value	Frequency	0	0 MHz	1	5	2	10	3	15	4	20	5	25	6	30	7	35	8	40	9	45	10	50	11	55	12	60	13	65	14	70	15	75	16	80	17	85	18	90	19	95	20	100	21	105	22	110	23	115	24	120	25	125	26	130	27	135	28	140	29-62	Not used
Value	Frequency																																																															
0	0 MHz																																																															
1	5																																																															
2	10																																																															
3	15																																																															
4	20																																																															
5	25																																																															
6	30																																																															
7	35																																																															
8	40																																																															
9	45																																																															
10	50																																																															
11	55																																																															
12	60																																																															
13	65																																																															
14	70																																																															
15	75																																																															
16	80																																																															
17	85																																																															
18	90																																																															
19	95																																																															
20	100																																																															
21	105																																																															
22	110																																																															
23	115																																																															
24	120																																																															
25	125																																																															
26	130																																																															
27	135																																																															
28	140																																																															
29-62	Not used																																																															

		63	Freq offset N/A
14-16	IST_PRF	Instrument PRF	
		Value	PRF
		0	2 KHz
		1	2.5
		2	3
		3	4
		4	5
		5	6
		6	7
		7	8
		8	9
		9	10
		10	11
		11	12
		12	13
		13-15	Not used
17	IST_S17	Spare	
18	IST_S18	Spare	
19	IST_S19	Spare	
20	IST_S20	Spare	
21	IST_S21	Spare	
22	IST_S22	Spare	
23	IST_S23	Spare	
24	IST_S24	Spare	
25	IST_S25	Spare	
26	IST_S26	Spare	
27	IST_S27	Spare	
28	IST_S28	Spare	
29	IST_S29	Spare	
30	IST_S30	Spare	
31	IST_S31	Spare	

Table 3-23 Level 1b MCD structure

Bit Number	Label	Description
0	MCD_DGR	High rate block degraded (0 - OK, 1 degraded) This bit is set if the following bits are set: MCD_BLK MCD_AGC MCS_ACQ
1	MCD_BLK	High rate block blank (0 – not blank, 1- blank)
2	MCD_CAA	CAL –A (TBC) characterisation (0) or data (1)
3	MCD_CAB	CAL –B (TBC) characterisation (0) or data (1)
4	MCD_CAC	CAL-C (TBC) characterisation or data (1)
5	MCD_AGC	AGC consistency (0 – OK, 1- Not OK)
6	MCD_ATT	Attitude correction (0 – Applied, 1 – Not applied)
7	MCD_ATC	Attitude Control in data (0 – used, 1 not used)
8	MCD_ROL	Roll threshold exceeded ($\pm 1^\circ$ for delivered data)
9	MCD_PTC	Pitch Threshold exceeded ($\pm 1^\circ$ for delivered data)
10	MCD_YAW	Yaw Threshold exceeded ($\pm 1^\circ$ for delivered data)
11	MCD_RSD	Roll standard deviation exceeded ($\pm 0.3^\circ$ for delivered data)
12	MCD_PSD	Pitch standard deviation exceeded ($\pm 0.3^\circ$ for delivered data)

13	MCD_YSD	Yaw standard deviation exceeded ($\pm 0.3^\circ$ for delivered data)
14	MCD_RCT	Roll correction applied across stack to correct phase difference over stack integration period – NOT USED IN OPERATIONAL PROCESSING
15	MCD_TRK	On-board Tracker varied during integration period of stack
16	MCD_ACQ	Instrument in acquisition sequence
17	MCD_S17	Spare
18	MCD_S18	Spare
19	MCD_S19	Spare
20	MCD_S20	Spare
21	MCD_S21	Spare
22	MCD_S22	Spare
23	MCD_S23	Spare
24	MCD_S24	Spare
25	MCD_S25	Spare
26	MCD_S26	Spare
27	MCD_S27	Spare
28	MCD_S28	Spare
29	MCD_S29	Spare
30	MCD_S30	Spare
31	MCD_S31	Spare

Table 3-24 Waveform group flags

Bit	Label	Description
0	BIT_L1B_WFM_APPROX	Approximate beam formation
1	BIT_L1B_WFM_EXACT	Exact beam formation
2	BIT_L1B_WFM_WEIGHTING_COMPUTED	Stack weighting and behaviour calculated
3	BIT_L1B_WFM_WEIGHTING_APPLIED	Beam weighting applied to stack
4	BIT_L1B_WFM_MULTILOOK_INCOMPLETE	Multi-looking incomplete - Full set of beams not included in the stack integration due to processor configuration angle limits.
5	BIT_L1B_WFM_ANGLE_ERROR	Azimuth steering angle error (applicable to approximate beam formation only). Nyquist angle limit exceeded.
6	BIT_L1B_WFM_ANTI_ALIAS	Anti aliased echoes computed
7	BIT_L1B_WFM_AUTO_FORM	Automatic beam formation use such that if the tracker changes by more than x metres between bursts (defined in processor configuration file: 'Beam_Form_Threshold') then exact beam formation is triggered. This facility is switched on/off in the processor configuration file by switching both 'Force_Approx_Former' and 'Force_Exact_Former' on.
8	BIT_L1B_WFM_RETRACK_ERROR	OCOG re-tracker error (0=OK, 1=ERROR)
9	BIT_L1B_WFM_OCOG_WIDTH_THRESH	0=OK, OCOG derived echo width exceeded=1 (Threshold in processor configuration file)
10	BIT_L1B_WFM_AZIMUTH_WEIGHTING	0=No weighting, 1=Hamming

		weighting applied to time domain burst prior to azimuth FFT
11	BIT_L1B_WFM_OCOG_RETRACK	0=OCOG Retracker not used, 1=OCOG Retracker used for re-tracker range and surface elevation
12	BIT_L1B_WFM_THRESHOLD_RETRACKER	0=Threshold Retracker not used, 1=Threshold Retracker used for range and surface elevation
13	BIT_L1B_WFM_SPARE_13	Spare
14	BIT_L1B_WFM_SPARE_14	Spare
15	BIT_L1B_WFM_SPARE_15	Spare

Table 3-25 Stack beam behaviour parameters

Field number	Description	Unit	Type	Size (bytes)
0	Stack Gaussian fit standard deviation	Beam/100	ss	2
1	Stack centre	Beam/100	ss	2
2	Amplitude	Scaled (can be converted to Watts using scaling factors)	ss	2
3	Skewness	Unitless/100	ss	2
4	Kurtosis	Unitless/100	ss	2
5	Spare	N/A	ss	2
6	Spare	N/A	ss	2
7	Spare	N/A	ss	2
8	Spare	N/A	ss	2
9	Spare	N/A	ss	2
10	Spare	N/A	ss	2
11	Spare	N/A	ss	2
12	Spare	N/A	ss	2
13	Spare	N/A	ss	2
14	Spare	N/A	ss	2
15	Spare	N/A	ss	2
16	Spare	N/A	ss	2
17	Spare	N/A	ss	2
18	Spare	N/A	ss	2
19	Spare	N/A	ss	2
20	Spare	N/A	ss	2
21	Spare	N/A	ss	2
22	Spare	N/A	ss	2
23	Spare	N/A	ss	2
24	Spare	N/A	ss	2
25	Spare	N/A	ss	2
26	Spare	N/A	ss	2
27	Spare	N/A	ss	2
28	Spare	N/A	ss	2
29	Spare	N/A	ss	2
30	Spare	N/A	ss	2
31	Spare	N/A	ss	2
32	Spare	N/A	ss	2
33	Spare	N/A	ss	2
34	Spare	N/A	ss	2
35	Spare	N/A	ss	2



36	Spare	N/A	ss	2
37	Spare	N/A	ss	2
38	Spare	N/A	ss	2
39	Spare	N/A	ss	2
40	Spare	N/A	ss	2
41	Spare	N/A	ss	2
42	Spare	N/A	ss	2
43	Spare	N/A	ss	2
44	Spare	N/A	ss	2
45	Spare	N/A	ss	2
46	Spare	N/A	ss	2
47	Spare	N/A	ss	2
48	Spare	N/A	ss	2
49	Spare	N/A	ss	2

3.2.6. Auxiliary Data Files

3.2.6.1. Instrument Characterisation Database (AUX_SIRDBF)

The instrument characterisation database contains a set of parameters relevant to the processing and calibration of ASIRAS measurement data. It also contains positional data for each relevant instrument with respect to the aircraft reference frame (see §4).

This database should not be confused with the CryoSat IPF database and consists of a different set of parameters.

3.2.6.2. Geophysical Constants (geophysical_constants)

The CryoSat PDS geophysical constants file is shown below. Note: some parameters will not be used in the ASIRAS processor; however, the file contents should remain the same.

```
<?xml version="1.0" encoding="UTF-8"?>
<Ipf_Const>
  <Fixed_Header>
    <File_Name>AS_OPER_CONST_000_20040324T000000_20041012T999999_0002.XML</File_Name>
    <File_Description>ASIRAS Geophysical constants</File_Description>
    <Notes></Notes>
    <Mission_Code>AS</Mission_Code>
    <File_Class>OPER</File_Class>
    <File_Type>CONST_000</File_Type>
    <File_Version>0001</File_Version>
    <Source>
      <System>name of the system</System>
      <Creator>Robert Cullen</Creator>
      <Creator_Version>04.00</Creator_Version>
      <Creation_Date>2005-07-19T16:55:13</Creation_Date>
    </Source>
  </Fixed_Header>
  <Variable_Header>
    <MPH></MPH>
    <SPH></SPH>
  </Variable_Header>
  <PI>
    <Description>pi greek</Description>
    <Value unit="unitless">3.141592653589793238</Value>
  </PI>
  <Deg_2_Rad>
    <Description>PI / 180</Description>
    <Value unit="">0.017453292514387740</Value>
  </Deg_2_Rad>
</Ipf_Const>
```



```
</Deg_2_Rad>
<C>
  <Description>speed of light in vacuo</Description>
  <Value unit="m/s">2.99792458e8</Value>
</C>
<K>
  <Description>Boltzmann Constant</Description>
  <Value unit="J/K">1.380662e-23</Value>
</K>
<W>
  <Description>angular speed of Earth rotation</Description>
  <Value unit="rad s^-1">7.29211585e-5</Value>
</W>
<Grav_Accl_Mu>
  <Description>Geocentric Gravitational Constant=g * mass of
Earth</Description>
  <Value unit="m^3 * s^-2 ">3.9860044e14</Value>
</Grav_Accl_Mu>
<J2>
  <Description>zonal harm. coef. of Earth grav.
potential</Description>
  <Value unit=" ">1082.65e-16 </Value>
</J2>
<J3>
  <Description>zonal harm. coef. of Earth grav.
potential</Description>
  <Value unit="">-2.543e-6 </Value>
</J3>
<J4>
  <Description>zonal harm. coef. of Earth grav.
potential</Description>
  <Value unit="">-1.6715e-6 </Value>
</J4>
<Ellipsoid>
  <Description>Name of reference ellipsoid</Description>
  <Value unit="">WGS84</Value>
</Ellipsoid>
<R_Equator>
  <Description>semi-major axis of reference ellipsoid</Description>
  <Value unit="Metres">6378137.000</Value>
</R_Equator>
<R_Pole>
  <Description>semi-minor axis of reference ellipsoid</Description>
  <Value unit="Metres">6356752.3142</Value>
</R_Pole>
<Flattening>
  <Description>flattening of reference ellipsoid</Description>
  <Value unit="unitless">0.00335281066</Value>
</Flattening>
<Sec_In_Day>
  <Description>Seconds in a day</Description>
  <Value unit="sec">86400</Value>
</Sec_In_Day>
</Ipf_Const>
```

3.2.6.3. Reference Instrument Position (AUX_POSITI)

The instrument location files have mandatory usage in both ASIRAS 04_02 Level 1A and Level 1b processors. Each platform has its own file since antenna positions, for example, are unique to each platform. In addition to localisation of antennas the file provides details of cables for group delay and loss that are different between platforms. An example for the Air Greenland Twin Otter is provided below. Details of these files are provided in the SPH part of the ASIRAS L1b file. For example:

In the product 'AS3TA00_ASIAL1B030920080420T113600_20080420T114224_0002.DBL' one finds:

```
ACQUISITION_STATION="DNSC Twin Otter  "
```

and

```
DS_NAME="IPF_POSITIONS  "
```



FILENAME="AS_OPER_AUX_DNSCTO_0000000T000000_9999999T999999_0001.XML "

AS_OPER_AUX_DNSCTO_0000000T000000_9999999T999999_0002.XML

```
<?xml version="1.0"?>
<AUX_Positions>
  <AUX_Positions_Header>
    <Fixed_Header>
      <File_Name>AS_OPER_AUX_DNSCTO_0000000T000000_9999999T999999_0002.XML</File_Name>
      <File_Description>ASIRAS and auxiliary position data for DNSC Twin
      Otter</File_Description>
      <Notes>The aircraft mechanical reference frame (AMR) is defined as a right hand
      coordinate system for which instrumentation reference positions are described.
      See CS-LI-ESA-GS-0371 issue 1.5 for full definition.
      The origin of the AMR for DNSCTO is the Front GPS antenna. The x-axis is
      in the nominal direct of motion of the aircraft (with no external horizontal or vertical
      forcing) in the direction through the nose of the aircraft. Th y-axis is orthogonal to the x-
      axis in the direction of the right hand wing (whilst facing in the forward direction). The z-
      axis is orthogonal to the x-y plane and points downwards. This reference frame is otherwise
      known as a north-east-down frame with respect to the WGS-84 ellipsoid.
      Issue 2: Cable delay and loss added</Notes>
      <Mission_Code>AS</Mission_Code>
      <File_Class>OPER</File_Class>
      <File_Type>AUX_DNSCTO</File_Type>
      <File_Version>0002</File_Version>
      <Platform>DNSC Twin Otter</Platform>
      <Source>
        <System>name of the system</System>
        <Creator>Robert Cullen</Creator>
        <Creator_Version>01.00</Creator_Version>
        <Creation_Date>2008-06-06T08:51:00</Creation_Date>
      </Source>
    </Fixed_Header>
    <Variable_Header>
      <MPH></MPH>
      <SPH></SPH>
    </Variable_Header>
  </AUX_Positions_Header>
  <Data_Block type="xml">
    <Cable_Group_Delay_Rx1>
      <Description>Cables attaching ASIRAS instrument to it's antennas cause a path
      delay and are platform specific. Existing cable are 1.8 meters and 1.0 metres. VALUES ARE
      APPROXIMATE</Description>
      <Value unit="ps">12008.</Value>
    </Cable_Group_Delay_Rx1>
    <Cable_Group_Delay_Rx2>
      <Description>Cables attaching ASIRAS instrument to it's antennas cause a path
      delay and are platform specific. Existing cable are 1.8 meters and 1.0 metres. VALUES ARE
      APPROXIMATE</Description>
      <Value unit="m">12008.</Value>
    </Cable_Group_Delay_Rx2>
    <Cable_Loss_Rx1>
      <Description>Cables attaching ASIRAS instrument to it's antennas cause a path
      loss and are platform specific. Existing cable are 1.8 meters and 1.0 metres. VALUES ARE
      APPROXIMATE</Description>
      <Value unit="dB">-6.3</Value>
    </Cable_Loss_Rx1>
    <Cable_Loss_Rx2>
      <Description>Cables attaching ASIRAS instrument to it's antennas cause a path
      loss and are platform specific. Existing cable are 1.8 meters and 1.0 metres. VALUES ARE
      APPROXIMATE</Description>
      <Value unit="dB">-6.3</Value>
    </Cable_Loss_Rx2>
    <COM_Reference>
      <Description>General Instrument measurements reference vector [x,y,z] in the
      aircraft mechanical reference frame</Description>
      <XYZ_Coord>
        <X unit="mm">-3185.0</X>
        <Y unit="mm">+470.0</Y>
        <Z unit="mm">+2005.0</Z>
      </XYZ_Coord>
      <Note>This is currently set to the ASIRAS baseline centre for DNSC Twin
```



```
Otter</Note>
  </COM_Reference>
  <SIR_Ant_1_Ref_Point>
    <Description>Antenna 1 Reference Point [x,y,z] in aircraft mechanical reference
frame</Description>
    <XYZ_Coord>
      <X unit="mm">-3185.00</X>
      <Y unit="mm">+85.0</Y>
      <Z unit="mm">+2005.0</Z>
    </XYZ_Coord>
    <Note>This is an approximate measurement for DNSC Twin Otter</Note>
  </SIR_Ant_1_Ref_Point>
  <SIR_Ant_2_Ref_Point>
    <Description>Antenna 2 Reference Point [x,y,z] in aircraft mechanical reference
frame</Description>
    <XYZ_Coord>
      <X unit="mm">-3185.0</X>
      <Y unit="mm">+855.0</Y>
      <Z unit="mm">+2005.0</Z>
    </XYZ_Coord>
    <Note>This is an approximate measurement for DNSC Twin Otter</Note>
  </SIR_Ant_2_Ref_Point>
  <GPS_Front_Ref_Point>
    <Description>Front GPS reference point location in aircraft mechanical fixed
frame</Description>
    <XYZ_Coord>
      <X unit="mm">+0.0</X>
      <Y unit="mm">+0.0</Y>
      <Z unit="mm">+0.0</Z>
    </XYZ_Coord>
    <Note>This is defined as the AMR origin DNSC Twin Otter</Note>
  </GPS_Front_Ref_Point>
  <GPS_Rear_Ref_Point>
    <Description>Rear GPS reference point location in aircraft mechanical fixed
frame</Description>
    <XYZ_Coord>
      <X unit="mm">-3700.0</X>
      <Y unit="mm">+870.0</Y>
      <Z unit="mm">+160.0</Z>
    </XYZ_Coord>
    <Note>This is an approximate measurement for DNSC Twin Otter</Note>
  </GPS_Rear_Ref_Point>
</Data_Block>
</AUX_Positions>
```

3.2.6.4. IERS Bulletin B (AUX_ASIBUB)

IERS bulletin data is required in order to convert from UTC, as specified by the ASIRAS, GPS and INS systems, to TAI. TAI is timing reference used on CryoSat. See [R5].

3.2.6.5. Corner Reflector Position (AUX_TRANSP)

It is sometimes necessary to use a known corner reflector position in the level 1b processing in order to correctly analyse the response. Below is an example of such a file

```
Number_Transponders=+00001<Transponders>
Trans_Lat_1=+7.0543790000000000E+01<Deg T 21 Corner reflector Autumn campaign 14 Sep 2004 - LM
first values>
Trans_Lon_1=-4.3025228333300000E+01<Deg>
Trans_Elev_1=+2.7418540000000000E+03<m>
```

3.2.6.6. Geocorrection files

There are no geo-correction files to be used in association with the version 04.02 (and earlier versions) of the ASIRAS processor.

3.2.7. Calibration Files

There are no Calibration file types used in association with version 4.02 (and earlier versions) of the ASIRAS processor. Some calibration corrections are contained within the ASIRAS IPF database file.

3.2.8. Job orders

Job orders are files containing all files necessary for processing ASIRAS data. Parameters contained in the job order as described in the following table.

Table 3-26 Level 1 Job order fields

Element	Type	Format	Mandatory /Optional	Description
Geophysical Constants	File	%s	M	Contains all geophysical constants
Start	Time	yyyymmdd_hhmmss	M	Used to initialise ESA Earth Explorer CFI for conversion of UTC to TAI
Stop	Time	yyyymmdd_hhmmss	M	Used to initialise ESA Earth Explorer CFI for conversion of UTC to TAI
Task_Name		%7c	M	“ASI_L1_” HAM-SARIn “ASI_L1_LAM” LAM-SAR & LAM-A-SAR
Task_Version		%f	M	Software version 4.02 (SARIn) 4.02 (LAM, LAM-A)
Processor Conf	File	%s	M	Processor configuration file
Input File Types				
AUX_ASIBUB	File	%s	M	Bulletin B file for time correlation
AUX_SIRDBF	File	%s	M	ASIRAS IPF database
ASI_RX1_L0	File	%s	M	Receive chain 1 measurement file
ASI_RX2_L0		%s	M	Receive chain 2 measure ASI_LOG_L0 measurement file
ASI_LOG_L0		%s	M	ASIRAS Log file
AUX1ASINAV		%s	M	Inertial navigation system file
AUX2ASIGPR		%s	O	Rear DGPS processed GPS – note must be used if AUX2ASIGPF not available
AUX2ASIGPF		%s	O	Front DGPS processed GPS – note must be used if AUX2ASIGPR not available.
AUX3ASIGPR		%s	O	Deleted
AUX3ASIGPF		%s	O	Deleted
AUXBASIGPR		%s	O	Rear DGPS (Binary big endian)
AUXBASIGPF		%s	O	Front DGPS (binary big endian)
AUX_POSITI		%s	M	Instrument position files described in the aircraft mechanical reference frame
Output File types				
ASI_SIN_L1		%s	O	L1 format containing Measurement echoes. (Obsolete due to large file sizes)
ASI_SINAL1		%s	O	L1 format containing pointer to Measurement echo number.
Breakpoint File Types				
BKPSINPASIL BKPLAMPASIL			O	Parameters extracted from
BKPSINPNAV BKPLAMPNAV			O	Extraction of navigation data from INS file
BKPSINPMEA BKPLAMPMEA			O	Measurement data
BKPSINPLOG BKPLAMPLOG			O	General log messages
BKPSINPFI_ BKPLAMPFI			O	Floating point L1 data
BKPSINPGPS BKPLAMPGPS			O	Interpolated DGPS file
BKPSINPSTV BKPLAMPSTV			O	State vector file
BKPSINPSUS BKPLAMPUSUS			O	Ellipsoid locations of aircraft at L1 record timestamp
BKPSINPATT				Conversion of INS to pointing angles and



BKPLAMPATT				determination of real beam and interferometric baseline

Table 3-27 Level 1b Job order fields

Element	Type	Format	Mandatory /Optional	Description
Geophysical Constants	File	%s	M	Contains all geophysical constants
Start	Time	yyyymmdd_hhmmss	M	Used to initialise ESA Earth Explorer CFI for conversion of UTC to TAI
Stop	Time	yyyymmdd_hhmmss	M	Used to initialise ESA Earth Explorer CFI for conversion of UTC to TAI
Task_Name		%7c	M	“ASI_L1B” (HAM-SARIn) “ASI_L1B_LAM” (LAM-SAR) “ASI_L1B_LAMA” (LAM-A-SAR)
Task_Version		%f	M	Software version 4.02 (HAM-SARIn) 4.02 (LAM), 4.02 (LAM-A)
Processor_Conf	File	%s	M	Processor configuration file
Input File Types				
AUX_ASIBUB	File	%s	M	Bulletin B file for time correlation
AUX_SIRDBF	File	%s	M	ASIRAS IPF database
ASI_SIN_L1	File	%s	M	Level 1 data with measurement echoes (obsolete due to file sizes)
ASI_SINAL1		%s	O	Level 1 data with pointers to measurement echoes
ASI_RX1_L0		%s	O	If ASI_SINAL1 is used then measurement echoes are required.
ASI_RX1_L0		%s	O	
AUX_TRANSP		%s	O	Corner reflector position data file
AUX_POSITI		%s	M	Instrument position files described in the aircraft mechanical reference frame
Output File types				
ASI_SIN_1B		%s	O	HAM-SARIn level 1b file
ASI_LAM_1B		%s	O	LAM-SAR & LAM-A-SAR level 1b file
Breakpoint File Types				
BKPSINSFFT			O	2-D FFT output of acquired bursts
BKPLAMSFFT				
BKPSINSSUS			O	L1b surface locations
BKPLAMSSUS				
BKPSINSF1			O	Time domain bursts of complex echoes
BKPLAMSF1				
BKPSINSAEL			O	Measurement data
BKPLAMSAEL				
BKPSINSF1B			O	Floating point L1b data
BKPLAMSF1B				
BKPSINSLES			O	Surface locations on and across track
BKPLAMSLES				
BKPSINSUPT			O	Unpacked level 1 output data
BKPLAMSUPT				
BKPSINSAEL			O	Surface locations file
BKPLAMSAEL				
BKPSINSINT			O	Intersection data file
BKPLAMSINT				
BKPSINSBED			O	Pre beam formation burst output
BKPLAMSBED				
BKPSINSMUL			O	Multi look data
BKPLAMSMUL				
BKPSINSSLA			O	Slant range output data
BKPLAMSSLA				
BKPSINSSSS			O	Stack data file
BKPLAMSSSS				
BKPSINSPBF			O	Pre beam formation burst output
BKPLAMSPBF				
BKPSINSSBR			O	Pre beam formation post phase shift burst output
BKPLAMSSBR				



BKPSINSPBS BKPLAMSPBS			O	Post beam formation
BKPSINSABF BKPLAMSABF			O	After beam formation pre phase multiplication
BKPSINSAPS BKPLAMSAPS			O	After beam formation post phase multiplication
BKPSINSRAC BKPLAMSRAC			O	Range compression output
BKPSINSJP1 BKPLAMSJP1			O	Jepensson Flite Map format location data from L1 data
BKPSINSJP2 BKPLAMSJP2			O	Jepensson Flite Map format location data from L1B data
BKPSINSSUS BKPLAMSSUS			O	L1b surface locations

3.2.9. Processor Configuration File (Processor_Conf)

The processor configuration file is fixed for Version 4.02 of the ASIRAS software. It contains a number of switches and tunable thresholds necessary for processing the ASIRAS measurement data. An example of this file is reproduced in §6.1 complete with parameter descriptions.

3.2.10. LD90 processed data structure

Ld90 ASCII processed data includes latitude/longitude and surface elevation (with respect to a reference ellipsoid) vectors in the WGS-84 reference frame for every single laser shot point. The data is time stamped at a rate of exactly 4 Hz, corrected for timeshifts, squint angle and INS.

Table 3-28 LD90 processed data record structure

Identifier	Description	Unit	Format (ASCII)	Size (chars)
1	Days	UTC	DD	
2	Months		MM	
3	Years		YYYY	
4	Hours		Hh	
5	Minutes		Mm	
6	Seconds		Ss	
7	Latitude of GPS (DGPS processed w.r.t WGS-84)	Degrees	+-.000.000000000	
8	Longitude (DGPS processed w.r.t WGS 84)	Degrees	+-.000.000000000	
9	Geodetic Height above WGS-84 reference ellipsoid	m	+-.0000.00000	

3.2.11. ALS processed data structure

ALS data structure is written in big endian format and described in the following table:

Table 3-29 ALS Level_L1 data structure (obtained from AWI)

Field	Description	Units	Bytes	Format
-------	-------------	-------	-------	--------



#				
	RAW HEADER		Total = 57	
	HEADER PREAMBLE BLOCK		Total = 10	
#1	HEADER PREAMBLE BLOCK HEADERSIZE		4	ULON
#2	HEADER PREAMBLE BLOCK DATASETLEN		2	UINT
#3	HEADER PREAMBLE BLOCK PROTOCOLID		1	BYTE
#4	SYNC FIELD		1	BYTE
#5	CRC FIELD		1	BYTE
#6	HEADER PREAMBLE BLOCK HEADERID		1	BYTE
	HEADER MAIN BLOCK		Total = 24	
#7	HEADER MAIN BLOCK MEASOFFSET		2	UINT
#8	HEADER MAIN BLOCK MEASSIZE		2	UINT
#9	HEADER MAIN BLOCK MEASCOUNT		2	UINT
#10	HEADER MAIN BLOCK LEADINID		1	BYTE
#11	HEADER MAIN BLOCK LEADINIDSUB		2	UINT
#12	HEADER MAIN BLOCK MEASIDMAIN		1	BYTE
#13	HEADER MAIN BLOCK MEASIDSUB		2	UINT
#14	ENABLE RANGE OUTPUT		1	BYTE
#15	ENABLE AMPLITUDE OUTPUT		1	BYTE
#16	ENABLE ANGLE OUTPUT		1	BYTE
#17	ENABLE QUALITY OUTPUT		1	BYTE
#18	ENABLE SYNC TIMER OUTPUT		1	BYTE
#19	ENABLE TRUE COLOR OUTPUT		1	BYTE
#20	HEADER MAIN BLOCK TRAILERIDMAIN		1	BYTE
#21	HEADER MAIN BLOCK TRAILERIDSUB		2	UINT
#22	HEADER MAIN BLOCK PARAMETERIDMAIN		1	BYTE
#23	HEADER MAIN BLOCK PARAMETERIDSUB		2	UINT
	HEADER PARAMETER BLOCK		Total = 23	
#24	HEADER PARAM BLOCK SERIALNUMBER		8	8 * BYTE
#25	HEADER PARAM BLOCK RANGEUNIT		4	FLT
#26	HEADER PARAM BLOCK ANGLEUNIT		4	FLT
#27	HEADER PARAM BLOCK TIMERUNIT		4	FLT
#28	HEADER PARAM BLOCK POLARANGLEID		1	BYTE
#29	HEADER PARAM BLOCK HWRES		1	BYTE
#30	HEADER PARAM BLOCK TARGET		1	BYTE
	PROC HEADER		Total = 36	
#31	PROC HEADER SIZE		1	BYTE
#32	NUMBER OF SCAN LINES		4	ULON
#33	NUMBER OF DATA POINTS PER LINE		1	BYTE
#34	NUMBER OF SYNCOUNTER		4	ULON
#35	NUMBER OF TRIG COUNTER		4	ULON
#36	BYTES PER LINE		2	UINT
#37	BYTES SEC LINE		8	ULON64
#38	YEAR	YYYY	2	UINT
#39	MONTH	MM	1	BYTE
#40	DAY	DD	1	BYTE
#41	STARTTIME_SEC	Sec. of the day	4	ULON
#42	STOPTIME_SEC	Sec. of the day	4	ULON
#43	LINE_TIMESTAMP	Sec. of the day	BYTES_SEC_LINE (= 4 * NUMBER OF SCAN LINES)	ULON
	DATA		Total = BYTES_PER_LINE * NUMBER OF SCAN LINES	
	DATA_LINE		BYTES_PER_LINE	
#44	LASER SHOTTIME_SEC	Sec of	4 * NUMBER_OF_DATA	ULON



#45	LASER_SHOTTIME_MICSEC	the day	POINTS PER LINE	ULON
		Sec of the day	4 * NUMBER_OF_DATA POINTS PER LINE	
#46	ANGLE	10 ⁻⁴ Deg	4 * NUMBER_OF_DATA POINTS PER LINE	LON
#47	RANGE	10 ⁻³ m	4 * NUMBER_OF_DATA POINTS PER LINE	ULON
#48	AMPLITUDE		NUMBER_OF_DATA POINTS PER LINE	BYTE
#49	QUALITY		NUMBER_OF_DATA POINTS PER LINE	BYTE
#50	RED		2 * NUMBER_OF_DATA POINTS PER LINE	UINT
#51	GREEN		2 * NUMBER_OF_DATA POINTS PER LINE	UINT
#52	BLUE		2 * NUMBER_OF_DATA POINTS PER LINE	UINT
#53	TRAILER_SYNCCOUNTER		4	ULON

3.2.12. □□□□□□□□ ALS Level 1b DEM format

DEMs are stored in ALS processed L1b data with the following one of two data formats. The first covers version 1 of the CryoVEx 2004a and b data

(Note: AWI version 1 data release Feb 2006 for CryoVEx 2004 and Bay of Bothnia 2005 contains NaN [Not a Number] when laser data points are not present – this and the following format may be changed in a future release of the data)

3.2.12.1. ASL AWI Level 1b (CryoVEx 2004 A and B version 1 data)

This data format was defined by AWI during the CryoVEx 2004 campaign processing after which it was realised there were certain shortfalls. The format has been superseded that described in §3.2.12.2. The format described in this section will become obsolete with CryoVEx 2004 version 2 processing and any subsequent data processing.

Note: The format does not apply to any other campaign other than those of 2004.

Header

Field #	Description	Units	Type	Size (bytes)
1	Header size	Bytes	uc	1
2	Number of scan lines, N_{als_scan}	lines	ul	4
3	Number of data points per line, N_{als_dppl}	points	uc	1
4	Bytes per line, N_{als_bbl}	bytes	us	2
5	Bytes sec line	bytes	ull	8
6	Bytes micro second line	bytes	ull	8
7	Year of acquisition (UTC)	year	us	2
8	Month of acquisition (UTC)	Month	uc	1
9	Day of acquisition (UTC)	Day	uc	1
10	Acquisition start time (UTC)	Seconds of day	ul	4
11	Acquisition stop time	Seconds of day	ul	4
12	Device name (LMS-Q280)	N/A	uc	8
Total (Bytes)				44

Timestamp header array relating to scan line acquisition (Data start= Byte 44)

1	Array of time stamps (seconds) related to scan line acquisition Note: Number of scan lines = N_{als_scan} is obtained from header above	Seconds	ul* Number of scan lines	$4 N_{als_scan}$
---	--	---------	--------------------------	-------------------

2	Array of time stamps (micro seconds) for each laser scan line. Note: Number of scan lines = N_{als_scan} is obtained from header above	Micro Seconds	ul*Number of scan lines	$4 N_{als_scan}$
Total (Bytes)				$8 N_{als_scan}$

DEM Record repeated N_{als_scan} times (**Data start**= $44 + 8N_{als_scan}$ bytes)

1	Array of Latitudes per data point ($0, N_{als_dppl} - 1$)	Deg	f	$4 N_{als_dppl}$
2	Longitude ($0, N_{als_dppl} - 1$)	Deg	f	$4 N_{als_dppl}$
3	Surface Elevation ($0, N_{als_dppl} - 1$)	Meters	f	$4 N_{als_dppl}$
Total (Bytes)				N_{als_bbl}

Total file size = $44 + 8 N_{als_scan} + N_{als_scan} N_{als_bbl}$

3.2.12.2. ALS AWI Level 1b (CryoVEx 2004 version 2 CryoVEx 2005 onwards)

This data format defined by AWI advances from the data format described in §3.2.12.1 which was an early data format. The main change. CryoVEx 2004 data will be reprocessed (version 2) at a data after release of this document at which time §3.2.12.1 will become obsolete.

ALS data can be ingested using the IDL routine 'read_als.pro'

Header

Field #	Description	Units	Type	Size (bytes)
1	Header size	Bytes	uc	1
2	Number of scan lines, N_{als_scan}	lines	ul	4
3	Number of data points per line, N_{als_dppl}	points	uc	1
4	Bytes per line, N_{als_bbl}	bytes	us	2
5	Bytes sec line	bytes	ull	8
6	Year of acquisition (UTC)	year	us	2
7	Month of acquisition (UTC)	Month	uc	1
8	Day of acquisition (UTC)	Day	uc	1
9	Acquisition start time (UTC)	Seconds of day	ul	4
10	Acquisition stop time	Seconds of day	ul	4
11	Device name (LMS-Q280)	N/A	uc	8
Total (Bytes)				36

Timestamp header array relating to scan line acquisition (Data start= Byte 36)

1	Array of time stamps (seconds) related to scan line acquisition Note: Number of scan lines = N_{als_scan} is obtained from header above	Seconds	ul* Number of scan lines	$4 N_{als_scan}$
Total (Bytes)				$4 N_{als_scan}$

DEM Record repeated N_{als_scan} times (**Data start**= $36 + 4N_{als_scan}$ bytes)

1	Time	Second of the day	d	$8 N_{als_dppl}$
---	------	-------------------	---	-------------------



Ref.:CS-LI-ESA-GS-0371

Issue: 2.6

Date: 01/06/2009

Page: 74 / 119

2	Array of Latitudes per data point ($0, N_{als_dpl} - 1$)	Deg	d	$8 N_{als_dpl}$
3	Longitude ($0, N_{als_dpl} - 1$)	Deg	d	$8 N_{als_dpl}$
4	Surface Elevation ($0, N_{als_dpl} - 1$)	Meter	d	$8 N_{als_dpl}$
Total (Bytes)				N_{als_bbl}

$$\text{Total file size} = 36 + 4 N_{als_scan} + N_{als_scan} N_{als_bbl} = 36 + 4 N_{als_scan} + 32 N_{als_dpl}$$

3.2.13. Processed HEM data format

The EM data is delivered in blank separated ASCII data format described below. All time tags are standard UTC time.

Column	Description	Format	Unit
1	Year	I4	-
2	Month	I2	-
3	Day	I2	-
4	Time	F8.2	Seconds of the day
5	Fiducial Number	I9	-
6	Latitude	F12.7	Degree
7	Longitude	F12.7	Degree
8	Distance	F12.3	Meter
9	Thickness	F8.3	Meter
10	Laser range	F8.3	Meter

Table 3-30 HEM data format.

One flight is separated into several profiles with a calibration at the beginning and the end. The distance flown is calculated for this individual profiles and therefore not cumulative for the entire flight. The fiducial number can be discontinuous if a reboot of the system was necessary during the flight.

4. ASIRAS Processing Reference Frames

This appendix describes all associated reference frames used to process ASIRAS data.

4.1. World Geodetic System (WGS-84)

The WGS-84 system is described in [R7]

Ellipsoidal parameters for the WGS-84 are:

Semi major axis, $a_e=6378137.0$ metres

Ellipsoidal flattening, $e=0.00335281066$

GPS, ASIRAS Level 1 and Level 1b positions are all described within this reference frame.

4.2. Global Earth Fixed Frame (GEF)

The GEF is related to the ITRF (described in 1.3) and WGS-84 and is used for processing ASIRAS data. The reference frame is defined here with respect to ASIRAS data processing. The origin of the reference frame is as defined by the ITRF. In the equatorial plane, the x-axis, $\hat{\mathbf{x}}_{ge}$, is fixed with longitude $\lambda = 0$ degrees. The y-axis, $\hat{\mathbf{y}}_{ge}$, is also in the equatorial plane, orthogonal to $\hat{\mathbf{x}}_{ge}$ and is in the direction of $\lambda = 90$ degrees. The z-axis, $\hat{\mathbf{z}}_{ge}$, forms the triple and is defined as, $\hat{\mathbf{z}}_{ge} = \hat{\mathbf{x}}_{ge} \wedge \hat{\mathbf{y}}_{ge}$.

The GEF axes have the following values:

$$\hat{\mathbf{x}}_{ge} = \{1,0,0\}, \hat{\mathbf{y}}_{ge} = \{0,1,0\}, \hat{\mathbf{z}}_{ge} = \{0,0,1\} \quad \text{Equation 4.2-1}$$

4.3. Aircraft Mechanical Reference Frame (AMR)

This fixed aircraft mechanical reference (AMR) frame is used to describe instrument reference point positions within. The origin of the AMR is different for each aircraft hosting ASIRAS and is described in the aircraft dependent auxiliary file AUX_POSITI (§3.2.6.3). In all cases The x-axis, $\hat{\mathbf{x}}_{am}$ is directed through the front nominal pointing of the aircraft, the y-axis, $\hat{\mathbf{y}}_{am}$, is directed orthogonal to the x-axis in the direction of the right hand wing. The triple is completed via the cross product $\hat{\mathbf{z}}_{am} = \hat{\mathbf{x}}_{am} \wedge \hat{\mathbf{y}}_{am}$.

The aircraft mechanical frame axes have the following values:

$$\hat{\mathbf{x}}_{am} = \{1,0,0\}, \hat{\mathbf{y}}_{am} = \{0,1,0\}, \hat{\mathbf{z}}_{am} = \{0,0,1\}. \quad \text{Equation 4.3-1}$$

It should be noted that the origin of the AMR will not be that of the moment of inertia of the aircraft. This ultimately will result in an error in the processing.

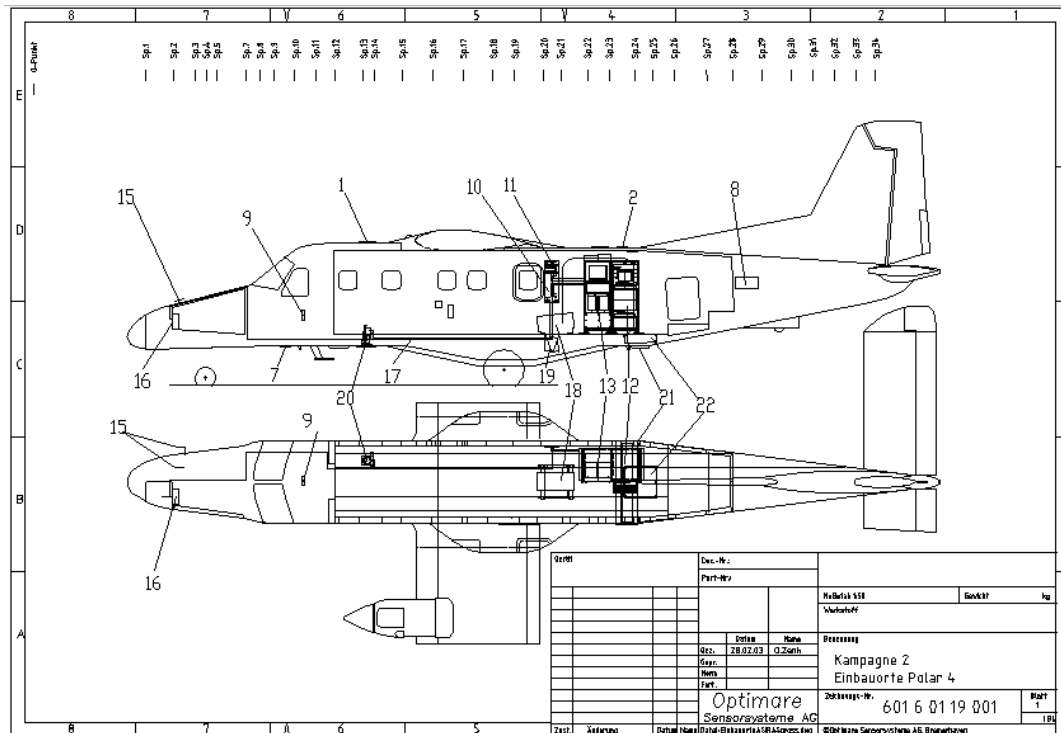

Figure 4-1 Positional information regarding instrumentation on Dornier DCODE

Coordinates in the following table were measured by ruler and spirit level some months prior to the CryoVex 2004 pre-campaign in March 2004 on the AWI/DLR DCODE.

Note positional information are platform dependent and are described in §3.2.6.3.

Description of aircraft fixed coordinate system:				
positive x - direction	Through nose of aircraft			
positive y - direction	to right wing side			
positive z - direction	Downwards ($x \wedge y$)			
Origin	TBD			
Components	X [mm]	Y[mm]	Z[mm]	
GPS-REAR (Pos. 2)	18	1398	-1819	GPS antenna bottom
GPS-FRONT (Pos. 1)	4836	561	-1996	GPS antenna bottom
RIEGL-LD90 (Pos. 19)	1180	763	+115	mid point of receiving and transmitting optic
RIEGL-LMSQ280 (Pos. 18)	1080	763	-441	Origin of measurement
RST-RADAR1 (Pos. 21)	-216	400	+15	Midpoint of patch antenna (Receive)
RST-RADAR2 (Pos. 21)	-216	1140	+15	Midpoint of patch antenna (Transmit)
Video Camera SONY (Pos. 20)	4446	1417	-100	midpoint of camera lenses

Table 4-1 Approximate locations for instrumentation on AWI/DLR DCODE

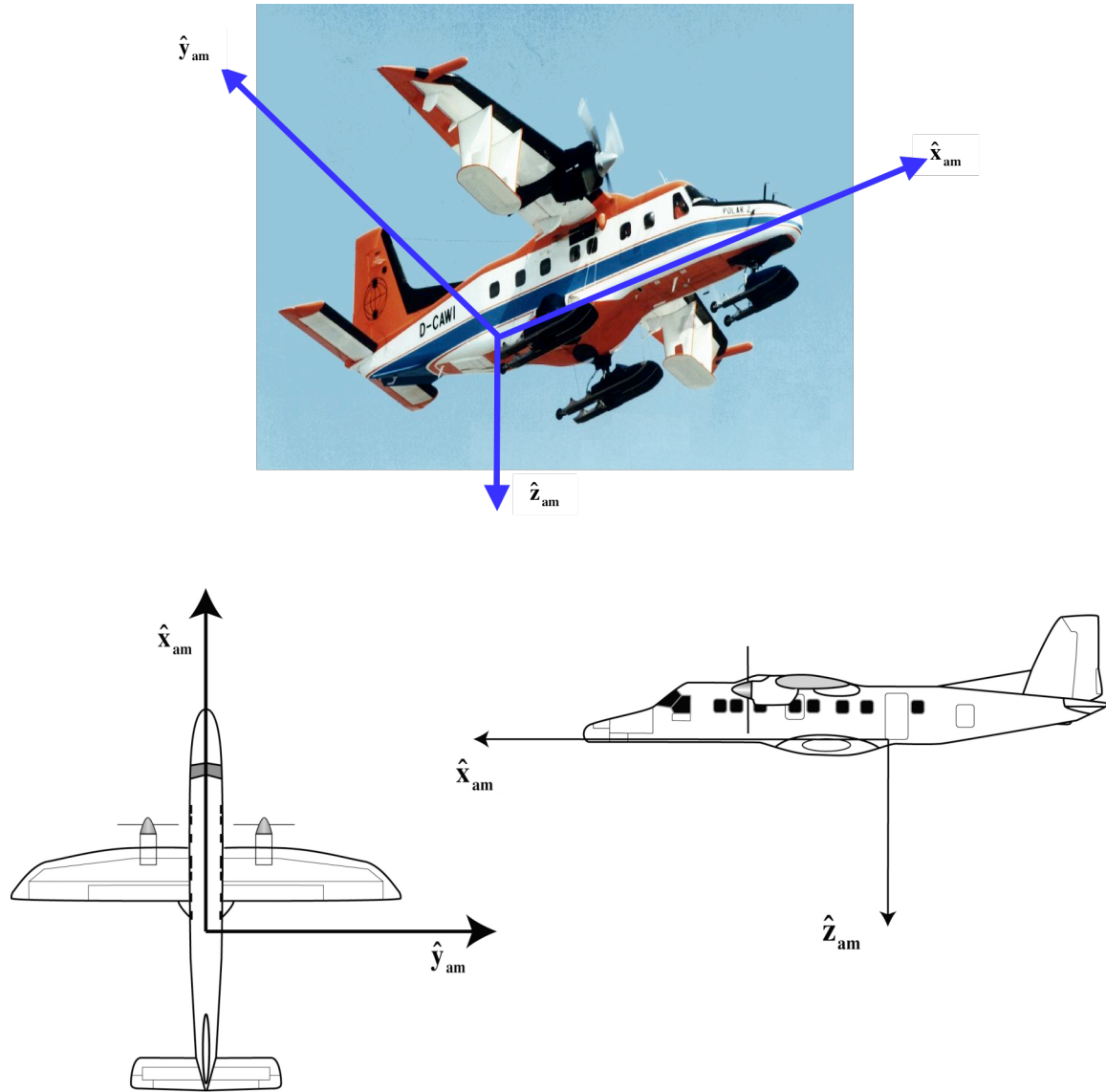

Figure 4-2 Aircraft mechanical reference frame diagram

4.4. Front GPS Reference Frame (GPS_F)

Note: GPS here refers to differentially processed GPS.

This aircraft fixed reference frame concerns the front GPS when it is available. This reference frame is time-variant, described with respect to the GEF and its origin is at the GPS antenna bottom (an Optimare term).

The z-axis, $\mathbf{z}_{gf}(\mathbf{t})$ is zenith to the ellipsoid (in the opposite direction to the ellipsoidal normal). This can be calculated by taking the GPS location described in the WGS-84 system, $\Phi_{gf}(\lambda, \phi, h, t)$, where, λ , is the

longitude in degrees, ϕ , is the geodetic latitude in degrees, h , is the geodetic height and t is the time of the measurement in UTC.

The vector, $\mathbf{z}_{gf}(t)$, is determined by first computing the GEF Cartesian locations of $\Phi_{gf}(\lambda, \phi, h, t)$ and $\Phi_{gf}(\lambda, \phi, 0, t)$ using the geodetic to GEF conversion described in 4.15. This provides 2 vectors, the ellipsoid surface position, $\mathbf{r}'_{gf}(\mathbf{x}, \mathbf{y}, \mathbf{z}, t)$ and the position of GPS_F, $\mathbf{r}_{gf}(\mathbf{x}, \mathbf{y}, \mathbf{z}, t)$. Note that $\mathbf{r}_{gf}(\mathbf{x}, \mathbf{y}, \mathbf{z}, t)$ is ellipsoidal normal to $\mathbf{r}'_{gf}(\mathbf{x}, \mathbf{y}, \mathbf{z}, t)$.

The axes are now computed:

$$\hat{\mathbf{z}}_{gf}(t) = \frac{\mathbf{r}'_{gf}(\mathbf{x}, \mathbf{y}, \mathbf{z}, t) - \mathbf{r}_{gf}(\mathbf{x}, \mathbf{y}, \mathbf{z}, t)}{|\mathbf{r}'_{gf}(\mathbf{x}, \mathbf{y}, \mathbf{z}, t) - \mathbf{r}_{gf}(\mathbf{x}, \mathbf{y}, \mathbf{z}, t)|} \quad \text{Equation 4.4-1}$$

$$\hat{\mathbf{y}}_{gf}(t) = \begin{cases} -\sin \lambda\pi/180 \\ \cos \lambda\pi/180 \\ 0 \end{cases} \quad \text{Equation 4.4-2}$$

$$\hat{\mathbf{x}}_{gf}(t) = \hat{\mathbf{y}}_{gf}(t) \wedge \hat{\mathbf{z}}_{gf}(t) \quad \text{Equation 4.4-3}$$

4.5. Rear GPS Reference Frame (GPS_R)

This aircraft reference frame concerns the rear GPS when it is available. This reference frame is time-variant, described with respect to the GEF and its origin is at the GPS antenna bottom (an Optimare term).

The method of determining this reference frame axes $\{\hat{\mathbf{x}}_{gr}(t), \hat{\mathbf{y}}_{gr}(t), \hat{\mathbf{z}}_{gr}(t)\}$ is identical to that of GPS_F with the exception the WGS-84 coordinates of GPS_R are described by $\Phi_{gr}(\lambda, \phi, h, t)$.

4.6. Nominal Aircraft Reference Frame (NAR)

It is not known which of the front or rear GPS is available. Since there will be differences in the GPS_F and GPS_R reference frames due to DGPS processing and also due to operation of the aircraft at low altitude an assumption has to be made regarding the NAR. We assume at low altitude this assumption is valid and $\{\hat{\mathbf{x}}_{gr}(t), \hat{\mathbf{y}}_{gr}(t), \hat{\mathbf{z}}_{gr}(t)\} = \{\hat{\mathbf{x}}_{gf}(t), \hat{\mathbf{y}}_{gf}(t), \hat{\mathbf{z}}_{gf}(t)\}$ and we take the NAR to be equal which ever of the front or rear GPS is available. In other words:

$$\text{If GPS_F is available } \begin{cases} \hat{\mathbf{x}}_{na}(t) \\ \hat{\mathbf{y}}_{na}(t) \\ \hat{\mathbf{z}}_{na}(t) \end{cases} = \begin{cases} \hat{\mathbf{x}}_{gf}(t) \\ \hat{\mathbf{y}}_{gf}(t) \\ \hat{\mathbf{z}}_{gf}(t) \end{cases}. \quad \text{Equation 4.6-1}$$

$$\text{If GPS_R is available, } \begin{cases} \hat{\mathbf{x}}_{na}(t) \\ \hat{\mathbf{y}}_{na}(t) \\ \hat{\mathbf{z}}_{na}(t) \end{cases} = \begin{cases} \hat{\mathbf{x}}_{gr}(t) \\ \hat{\mathbf{y}}_{gr}(t) \\ \hat{\mathbf{z}}_{gr}(t) \end{cases}. \quad \text{Equation 4.6-2}$$

The origin of this reference frame can be determined by first determining the AAR (described in the next section). However, since this reference frame is used entirely for its axes definition and not the origin we do not determine it here.

4.7. Actual Aircraft Reference Frame (AAR)

The AAR is defined as the NAR rotated about 3 axes using time-variant true heading, $\zeta(t)$, pitch, $\xi(t)$ and roll, $\eta(t)$, angles as determined from the time-shift corrected inertial navigation system (INS) data.

The reference frame, however, is computed in a number of stages.

First we take the AMR and rotate about the three angles (in units of radian) of rotation, $\zeta(t)$, $\xi(t)$ and $\eta(t)$ using the convention of application of rotations.

$$\begin{Bmatrix} \hat{\mathbf{x}}'_{aa}(t) \\ \hat{\mathbf{y}}'_{aa}(t) \\ \hat{\mathbf{z}}'_{aa}(t) \end{Bmatrix} = [\mathbf{R}_1(\eta(t)) \mathbf{R}_2(\xi(t)) \mathbf{R}_3(\zeta(t))]^T \begin{Bmatrix} \hat{\mathbf{x}}_{am}(t) \\ \hat{\mathbf{y}}_{am}(t) \\ \hat{\mathbf{z}}_{am}(t) \end{Bmatrix} \quad \text{Equation 4.7-1}$$

For testing purposes the rotations are kept separately but we also compute the direct direction cosine matrix from mechanical frame to rotated mechanical frame AA':

$$\mathbf{L}_a(t) = \begin{bmatrix} \hat{\mathbf{x}}_{am} \cdot \hat{\mathbf{x}}'_{aa}(t) & \hat{\mathbf{y}}_{am} \cdot \hat{\mathbf{x}}'_{aa}(t) & \hat{\mathbf{z}}_{am} \cdot \hat{\mathbf{x}}'_{aa}(t) \\ \hat{\mathbf{x}}_{am} \cdot \hat{\mathbf{y}}'_{aa}(t) & \hat{\mathbf{y}}_{am} \cdot \hat{\mathbf{y}}'_{aa}(t) & \hat{\mathbf{z}}_{am} \cdot \hat{\mathbf{y}}'_{aa}(t) \\ \hat{\mathbf{x}}_{am} \cdot \hat{\mathbf{z}}'_{aa}(t) & \hat{\mathbf{y}}_{am} \cdot \hat{\mathbf{z}}'_{aa}(t) & \hat{\mathbf{z}}_{am} \cdot \hat{\mathbf{z}}'_{aa}(t) \end{bmatrix}^T \quad \text{Equation 4.7-2}$$

We next determine the direction cosine matrix converting NAR to GEF.

$$\mathbf{L}_b(t) = \begin{bmatrix} \hat{\mathbf{x}}_{ge} \cdot \hat{\mathbf{x}}_{na}(t) & \hat{\mathbf{y}}_{ge} \cdot \hat{\mathbf{x}}_{na}(t) & \hat{\mathbf{z}}_{ge} \cdot \hat{\mathbf{x}}_{na}(t) \\ \hat{\mathbf{x}}_{ge} \cdot \hat{\mathbf{y}}_{na}(t) & \hat{\mathbf{y}}_{ge} \cdot \hat{\mathbf{y}}_{na}(t) & \hat{\mathbf{z}}_{ge} \cdot \hat{\mathbf{y}}_{na}(t) \\ \hat{\mathbf{x}}_{ge} \cdot \hat{\mathbf{z}}_{na}(t) & \hat{\mathbf{y}}_{ge} \cdot \hat{\mathbf{z}}_{na}(t) & \hat{\mathbf{z}}_{ge} \cdot \hat{\mathbf{z}}_{na}(t) \end{bmatrix} \quad \text{Equation 4.7-3}$$

A direction cosine matrix allowing conversion from the AAR to GEF is given by:

$$\mathbf{L}_{aa_to_ge}(t) = \mathbf{L}_b(t) \mathbf{L}_a(t) \quad \text{Equation 4.7-4}$$

4.8. Determination of ARR origin in ITRF and WGS-84 coordinates:

Depending on which GPS is available we have two measured (with TBD error) GPS locations in the mechanical reference frames for Do228-100 (Polar 4) are: $\mathbf{r}_{ma_gf} = \{4.836, 0.561, -1.996\}$ and $\mathbf{r}_{ma_gr} = \{0.018, 1.398, -1.819\}$.

If GPS_F is available then $\mathbf{r}_a = \mathbf{r}_{ma_gf}$ and $\mathbf{r}_{gps_itrf}(t) = \mathbf{r}_{gf}(t)$ as determined earlier (section GPS_F)

If GPS_R is available then $\mathbf{r}_a = \mathbf{r}_{ma_gr}$ and $\mathbf{r}_{gps_itrf}(t) = \mathbf{r}_{gr}(t)$ as determined earlier (section GPS_R)

Determine \mathbf{r}_a rotated into the GEF:

$$\mathbf{r}'_a(\mathbf{t}) = \mathbf{L}_{aa_to_ge}(\mathbf{t})\mathbf{r}_a$$

Equation 4.8-1

The Actual aircraft reference frame origin is given by:

$$\mathbf{r}_{aa}(\mathbf{t}) = \mathbf{r}_{gps_itrf}(\mathbf{t}) - \mathbf{r}'_a(\mathbf{t})$$

Equation 4.8-2

Actual aircraft reference frame origin described in WGS-84 coordinates, $\Phi_{aa}(x, y, z, t)$ is computed by using the function described in Appendix C.

4.9. Centre point of the ASIRAS baseline in ITRF and WGS-84 coordinates:

Given position vectors for 2 reference points of the left and right hand ASIRAS antennae, $\mathbf{r}_{as_tx_in_am}$ and $\mathbf{r}_{as_rx_in_am}$, the centre of baseline described in the mechanical frame is given by

$$\mathbf{r}_{cob_am} = \mathbf{r}_{as_tx_in_am} + \left(\frac{\mathbf{r}_{as_rx_in_am} - \mathbf{r}_{as_tx_in_am}}{2} \right)$$

Equation 4.9-1

In the ITRF these coordinates are given by:

$$\mathbf{r}_{cob_itrf}(\mathbf{t}) = \mathbf{r}_{aa}(\mathbf{t}) + \mathbf{L}_{aa_to_ge}(\mathbf{t})\mathbf{r}_{cob_am}$$

Equation 4.9-2

$\mathbf{r}_{cob_itrf}(\mathbf{t})$ is converted to WGS-84 coordinates, $\Phi_{cob}(x, y, z, t)$, via using the function described in §4.16.

4.10. Determination of yaw angle

The true heading, $\zeta(t)$, as extracted from the time shift corrected INS file contains the angle with respect to north of the AMR x-axis. However, the actual direction of motion may have some other component such that motion is described in the following diagram.

Figure 4-3. Yaw angle with respect to true heading of aircraft

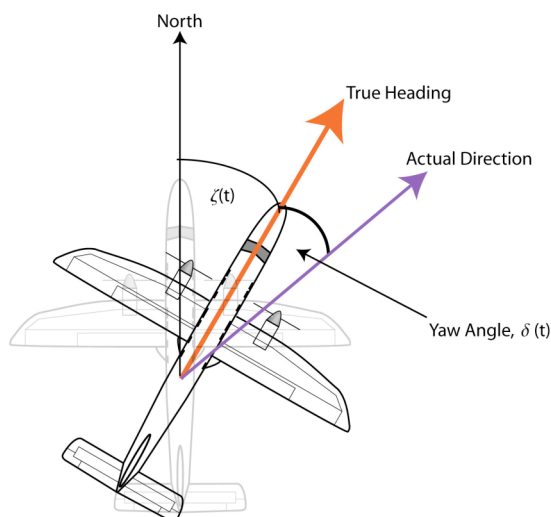

In this case there is an angle of yaw, $\delta(t)$, which is placed into the level 1 and level 1b products. The angle is calculated from actual direction vector, $\mathbf{v}_g(\mathbf{t})$ (calculated from rate of change of GPS locations), and the plane defined by the $\hat{\mathbf{x}}_{aa}(\mathbf{t}) - \hat{\mathbf{z}}_{aa}(\mathbf{t})$ plane described in the GEF.

The normal to the $\hat{\mathbf{x}}_{aa}(\mathbf{t}) - \hat{\mathbf{z}}_{aa}(\mathbf{t})$ plane is given by (essentially the y-axis):

$$\hat{\mathbf{n}}_{aap} = \hat{\mathbf{z}}_{aa} \wedge \hat{\mathbf{x}}_{aa}. \quad \text{Equation 4.10-1}$$

Rotated into the GEF this becomes time-variant:

$$\hat{\mathbf{n}}'_{aap}(\mathbf{t}) = \mathbf{L}_{aa_to_ge}(\mathbf{t}) \hat{\mathbf{n}}_{aap} \quad \text{Equation 4.10-2}$$

The yaw angle, $\delta(t)$, is given approximately by:

$$\delta(t) = \frac{\pi}{2} - \cos^{-1} \frac{v_g(t) \cdot \hat{\mathbf{n}}'_{aap}(t)}{|v_g(t)|} \quad \text{Equation 4.10-3}$$

4.11. Description of Level 1b Interferometric baseline and real-beam bore-sight vectors described in ASIRAS data processing reference frame

The ASIRAS level 1b parameters named interferometric baseline and real beam bore-sight are described in a reference frame different from those described in this document for consistency with the CryoSat level 1b products. Both these vectors are used to interpret interferometric phase difference in order to determine the echoing point on a surface. It should be noted that mispointing angles are not described within CryoSat products.

In this section the CryoSat Processing Reference Frame (CPRF) is described with respect to the AMR we show these vectors pictorially in Figure 4-4. Like the AMR the CPRF triple as applied to any given aircraft platform is fixed. With respect to the AMR the CPRF is given by the following,

$$\left\{ \begin{array}{l} \hat{\mathbf{x}}_c = \hat{\mathbf{z}}_{am} \\ \hat{\mathbf{y}}_c = \hat{\mathbf{x}}_{am} \\ \hat{\mathbf{z}}_c = -\hat{\mathbf{y}}_{am} \end{array} \right\} \quad \text{Eq. 4.11-1}$$

The baseline, $\hat{\mathbf{m}}_a$, and real beam, $\hat{\mathbf{m}}_b$, vectors are both described within CPRF and vary as a function of time as the aircraft attitude varies.

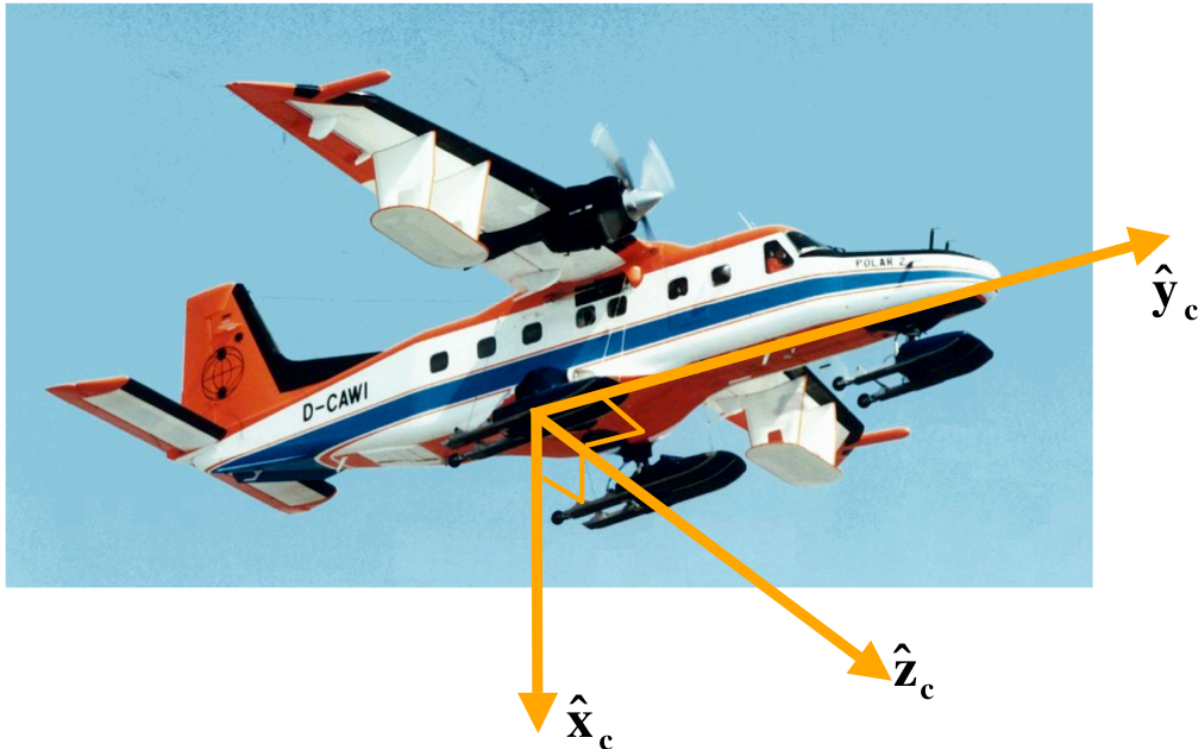

Figure 4-4 In order to remain compatible with CryoSat L1b products the baseline and real beam vectors are described with respect to the CPRF axes. Note: In the nominal configuration the transmit only antenna is on the right hand side if observing the front of the aircraft from the center location between the two antennas. The receive only antenna is on the left hand side. Also note the $\hat{\mathbf{z}}_c$ axis points into the page and is defined as the cross product between $\hat{\mathbf{y}}_c$ and $\hat{\mathbf{x}}_c$.

Note: If there is no mis-pointing of the platform the real beam and baseline vectors will be:

The real beam vector, \mathbf{m}_a , is parallel with $\hat{\mathbf{x}}_c$, hence $\mathbf{m}_a = \{1,0,0\}$ meters.

The interferometric baseline vector, \mathbf{m}_b , defined as the direction vector between the tx-rx antenna reference point (right hand side) to the rx only antenna reference point (left hand side) will be parallel to $\hat{\mathbf{z}}_c$. Hence, in this case, $\mathbf{m}_b = \{0,0,+1\}$ meters.

4.12. ASIRAS antenna reference frame with respect to AMR

On the Dornier Do-228-100 ASIRAS antennae were mounted such that the bore-sight of each antenna were pointing in the forward by $\sim 2.5^\circ$. This is not taken into account within the processing.

4.13. Rotation Matrices

Rotation matrices about axes 1, 2 and 3 (x,y,z) are provide the following rotations.

$$R_1(\alpha) = \begin{bmatrix} 1 & 0 & 0 \\ 0 & \cos\alpha & \sin\alpha \\ 0 & -\sin\alpha & \cos\alpha \end{bmatrix} \quad \text{Equation 4.13-1}$$

$$R_y(\alpha) = \begin{bmatrix} \cos\alpha & 0 & -\sin\alpha \\ 0 & 1 & 0 \\ \sin\alpha & 0 & \cos\alpha \end{bmatrix} \quad \text{Equation 4.13-2}$$

$$R_z(\alpha) = \begin{bmatrix} \cos\alpha & \sin\alpha & 0 \\ -\sin\alpha & \cos\alpha & 0 \\ 0 & 0 & 1 \end{bmatrix} \quad \text{Equation 4.13-3}$$

4.14. Coordinate system transforms

4.15. Determination GEF coordinates from WGS-84 geodetic coordinates

Input:

Symbol	Unit	Description
$\Phi(\lambda, \phi, h)$	(Deg,deg,m)	Geodetic location to be converted
λ	Deg	Longitude
ϕ	Deg	Geodetic latitude
h	m	Geodetic elevation
f_e	unitless	Earth ellipsoidal flattening (WGS-84)
a_e	m	Earth semi major axis (WGS-84)

Output:

Symbol	Unit	Description
$\mathbf{r}_{itrf}(\mathbf{x}, \mathbf{y}, \mathbf{z})$	m	Position vector described in ITRF

Computation:

1. Convert longitude to units of radian $\lambda' = \lambda\pi / 180$
2. Convert latitude to units of radian $\phi' = \phi\pi / 180$
3. Compute eccentricity,

$$e = \sqrt{f_e(2 - f_e)}$$

Equation 4.15-1

Compute East-West Curvature:

$$v = \frac{a_e}{\sqrt{1 - e^2 \sin^2 \phi}}$$

Equation 4.15-2

4. Determine GEF components:

$$\mathbf{r}_{\text{itrf}} = \begin{cases} (v + h) \cos \phi' \cos \lambda' \\ (v + h) \cos \phi' \sin \lambda' \\ ((1 - e^2)v + h) \sin \phi \end{cases}$$

Equation 4.15-3

4.16. Cartesian ITRF to Geodetic conversion

Input:

Symbol	Unit	Description
$\mathbf{r}_{\text{itrf}}(\mathbf{x}, \mathbf{y}, \mathbf{z})$	m	Position vector described in ITRF
f_e	unitless	Earth ellipsoidal flattening (WGS-84)
a_e	m	Earth semi major axis (WGS-84)
π	unitless	Pi
$E_h = 1 \times 10^{-12}$	unitless	Error limit for elevation measure
$E_\phi = 1 \times 10^{-12}$	rad	Error limit for latitude measure

Output:

Symbol	Unit	Description
$\Phi_{gd}(\phi, \lambda, h)$	(Degrees, Degrees, m)	WGS-84 geodetic coordinates

1. Set east-west curvature

$$n = 0$$

 The first iteration requires east-west curvature, $x_n = a_e$.

2. Compute square of the Earth's eccentricity

$$e^2 = f_e(2 - f_e)$$

Equation 4.16-1
3. Copy components of $\mathbf{r}_{\text{itrf}}(\mathbf{x}, \mathbf{y}, \mathbf{z})$ to variables, x, y, z .
4. Compute initial geodetic height estimate

$$h_n = \sqrt{x^2 + y^2 + z^2} - a_e \sqrt{1 - f_e}$$

Equation 4.16-2
5. Compute radius from x,y components

$$r_o = \sqrt{x^2 + y^2} \quad \text{Equation 4.16-3}$$

6. Compute initial estimate of latitude

$$\phi_n = \tan^{-1} \left(\frac{z / \sqrt{x^2 + y^2}}{1 - e^2 x / (x_n + h_n)} \right) \quad \text{Equation 4.16-4}$$

7. Iterate computation of ϕ_n and h_n until the error is less than E_{la} and E_{el} respectively

Do

$$n = n + 1$$

Calculate East-West Curvature

$$x_n = \frac{a_e}{\sqrt{1 - e^2 \sin^2 \phi_{n-1}}} \quad \text{Equation 4.16-5}$$

Calculate elevation

$$h_n = \frac{r_o}{\cos \phi_{n-1}} - x_n \quad \text{Equation 4.16-6}$$

Calculate latitude estimate

$$\phi_n = \tan^{-1} \left(\frac{z / r_o}{1 - e^2 x_n / (x_n + h_n)} \right) \quad \text{Equation 4.16-7}$$

Calculate Errors

$$E_{\phi_n} = \phi_n - \phi_{n-1} \text{ and } E_{h_n} = \frac{h_n - h_{n-1}}{a_e} \quad \text{Equation 4.16-8}$$

If $E_{\phi_n} > E_{\phi}$ OR $|E_{h_n}| > E_h$ then

$$\left. \begin{array}{l} x_n = x_{n-1} \\ h_n = h_{n-1} \\ \phi_n = \phi_{n-1} \end{array} \right\} \quad \text{Equation 4.16-9}$$

End if

If $E_{\phi_n} \leq E_{\phi}$ OR $|E_{h_n}| \leq E_h$ then exit loop

End do

8. Compute longitude

If $x = 0$ then

If $y = 0$ then $\lambda = 0$

If $y > 0$ then $\lambda = \pi/2$

If $y < 0$ then $\lambda = 3\pi/2$

End if

Otherwise:

$$\lambda = \tan^{-1}\left(\frac{y}{x}\right)$$

Equation 4.16-10

9. Correct the quadrant

If $y < 0$ AND $x > 0$ then

$$\lambda = \lambda + 2\pi$$

Else if $x < 0$ then $\lambda = \lambda + \pi$

10. Convert to degrees

$$\lambda = 180\lambda/\pi$$

Equation 4.16-11

$$\phi = 180\phi_n/\pi$$

Equation 4.16-12

5. File Naming Conventions

5.1. Campaign naming convention

Table 5-1 Campaign naming convention (e.g. ASIRAS_04_02)

AAAAAA	Identifier for Campaign (ASIRAS)
YY	Year
BB	Campaign number (e.g. ASIRAS_04_03 = third ASIRAS campaign 2004)

5.2. Raw ASIRAS data files

Raw measurement data files are named with the following format:

AYYMMDD_BB_C.dat

A	Identifier for Campaign (ASIRAS)
YY	Last 2 digits of the year (00-99)
MM	Numerical month number (01-12)
DD	Day of Month (01-31)
BB	Acquisition number of day (00-99)
C	Chain (1,2) Note LAM=2

5.3. De-sampled raw ASIRAS data files

De-sampled raw measurement data files are named with the following format:

AYYMMDD_BB_C_DE_XX.dat

A	Identifier for Campaign (ASIRAS)
YY	Last 2 digits of the year (00-99)
MM	Numerical month number (01-12)
DD	Day of Month (01-31)
BB	Acquisition number of day (00-99)
C	Chain (1,2) Note LAM=2
DE	De-sample identifier
XX	De-sample factor (01-99)

5.4. ASIRAS log files

ASIRAS log files that accompany are named with the following format:

AYYMMDD_BB.log

A	Identifier for Campaign (ASIRAS)
YY	Last 2 digits of the year (00-99)
MM	Numerical month number (01-12)
DD	Day of Month (01-31)
BB	Acquisition number of day (00-99)

5.5. Measuring day naming convention

Table 5-2 Measuring day naming convention

(e.g. 0409140501 – first acquisition flight at the fifth acquisition day at 14th Sep. 2004)

YY	Year
MM	Month
DD	DD
AA	Acquisition day number of Campaign
BB	Acquisition flight number of the day

5.6. ASIRAS Level 1b

File naming conventions loosely follow those of the Earth explorer file format guidelines [R3]. A change was made to this convention since it was deemed necessary to have the ASIRAS processor version stored within the file name. The Level 1b file name uses the following convention:

Files are named using the following construction:

AAIBCCC_DDDDDDDvVVVSSSSSSSSSSSSSS_PPPPPPPPPPPPPP_VVVV.DBL

Table 5-3 ASIRAS Level 1b file naming convention

AA	Mission identifier (AS) for ASIRAS	
I	Platform identifier: 1 AWI/DLR D-CODE 2 AWI/DLR Polar-4 3 DNSC Twin otter	
B	Processing type (T=TEST, O=Operational)	
CCC	Profile number from ASIRAS raw data (for example, A04=Fourth profile acquired on the date specified)	
DDDDDD	Processor name (ASILL1B=LAM, ASIAL1B=LAM-A, ASIWL1B (Windowed LAM/LAM-A) or ASIHL1B=HAM)	
vVVV	Software version (0201=version 2.01)	
SSSSSSSSSSSSSS	Start date from ASIRAS log (UTC)	
PPPPPPPPPPPPPP	Stop date from ASIRAS log (UTC)	
SSSSSSSSSSSSSS and PPPPPPPPPPPPPP are constructed from the following parameters		
	YYYY	Start Year (4)
	MM	Start Month (2)
	DD	Start Day (2)
	T	Separator between date and time
	HH	Start hour (2)
	MM	Start minute (2)
	SS	Start second (2)
VVVV	Processed data version (0001, 0002, etc)	

Table 5-4 Example file names

Data Set No. (H=HAM) (L=LAM)	Location	File name

H1	Austfonna	AS1TA04_ASIHL1B020120040420T181228_20040420T183624_0001.DBL
H2	Devon (North)	AS1TA01_ASIHL1B201_20040502T190503_20040502T191527_0001.DBL
H3	Devon (South)	AS1TA02_ASIHL1B201_20040502T192204_20040502T193135_0001.DBL
H4	EGIG T05	AS1TA00_ASIHL1B020120040909T160239_20040909T161212_0001.DBL
H5	EGIG T21	AS1TA03_ASIHL1B020120040914T163157_20040914T163803_0001.DBL
H6	EGIG (T19-T23)	AS1TA01_ASIHL1B020120040506T132808_20040506T141015_0001.DBL
L1	Bay of Bothnia	AS2TA09_ASILL1B030120050314T120700_20050314T120800_0001.DBL

5.7. DGPS file naming convention

AAA_B_CCCCCCCTSSSSSS_PPPPPP_VVVV.DBL

Table 5-5 GPS file naming convention (e.g. GPS_R_20040914T144202_185324_0001.DBL)

AAA	Identifier for GPS	
B	Identifier for: F – Front GPS antenna R – Rear GPS antenna	
CCCCCCC	Date of processed file	
Constructed from the following parameters		
	YYYY MM DD	Year Month Day
T	Seperator between date and time	
SSSSSS	Start time of processed file	
Constructed from the following parameters		
	hh mm ss	Start hour Start minute Start second
PPPPPP	Stop time of processed file	
Constructed from the following parameters		
	hh mm ss	Stop hour Stop minute Stop second
VVVV	Incremental processed data version (0001, 0002, etc.)	

5.8. Processed INS file convention

AAA_CCCCCCCTSSSSSS_PPPPPP_VVVV.DBL

Table 5-6 INS file naming convention (e.g. INS_20040914T144202_185324_0001.DBL)

AAA	Identifier for INS	
CCCCCCC	Date of processed file	
Constructed from the following parameters		
	YYYY MM DD	Year Month Day
T	Seperator between date and time	
SSSSSS	Start time of processed file	

Constructed from the following parameters		
	hh mm ss	Start hour Start minute Start second
PPPPPP	Stop time of processed file	
Constructed from the following parameters		
	hh mm ss	Stop hour Stop minute Stop second
VVVV	Incremental processed data version (0001, 0002, etc.)	

5.9. Processed Laser Scanner file (Digital Elevation Model) naming convention

AAA_BBB_RR_DDDDDDDDTSSSSSS_PPPPPP_VVVV.DBL

Table 5-7 Scanner file naming convention (e.g. ALS_L1B_A1_020040914T140350_160550_0001.DBL)

AAA	Identifier for Scanner (ALS)	
BBB	Processing level (L1 – Pre processed file with trigger pulse information; L1B – Processed L1 file: includes geolocated and corrected position of every single shot)	
RR	Grid spacing: A1 – AWI 2004 res ? m x ? m D1 – DNSC 1m x 1m D2 – DNSC 5m x5m	
DDDDDDDD	Date of processed file	
Constructed from the following parameters		
	YYYY MM DD	Year Month Day
T	Seperator between date and time	
SSSSSS	Start time of processed file	
Constructed from the following parameters		
	hh mm ss	Start hour Start minute Start second
PPPPPP	Stop time of processed file	
Constructed from the following parameters		
	hh mm ss	Stop hour Stop minute Stop second
VVVV	Incremental processed data version (0001, 0002, etc.)	

5.10. Processed LD90 file naming convention

AAAA_BBB_CCCCCCCTSSSSSS_PPPPPP_VVVV.DBL

Table 5-8 LD90 file naming convention (e.g. LD90_L1B_20040914T144202_185324_0001.DBL)

AAAA	Identifier for LD90
BBB	Processing version (L1B – Processed L1 file: includes geolocated and



		corrected position of every single shot)
CCCCCCCC Constructed from the following parameters		Date of processed file
	YYYY MM DD	Year Month Day
T		Seperator between date and time
SSSSSS Constructed from the following parameters		Start time of processed file
	hh mm ss	Start hour Start minute Start second
PPPPPP Constructed from the following parameters		Stop time of processed file
	hh mm ss	Stop hour Stop minute Stop second
VVVV		Incremental processed data version (0001, 0002, etc.)

5.11. Processed Helicopter electro-magnetic profiling (HEM) file naming convention

File: HEM_CMPID_SSSSSSSSSSSSSSS_PPPPPPPPPPPPPP.dat

CMPID	Campaign ID. Eg 'CRV08'
SSSSSSSSSSSSSS_PPPPPPPPPPPPPP	YYYYMMDDTHHMMSS=Start (UTC) YYYYMMDDTHHMMSS=Stop (UTC)



6. Auxiliary File Examples

6.1. Processor File Type Example (ASIRAS v04_02).

```
<?xml version="1.0" encoding="UTF-8"?>
<Ipfl_Conf>
<Processor_Configuration_Header>
  <Fixed_Header>
    <File_Name>AS_OPER_PCONF_____20070401T000000_20070501T999999_0001.XML</File_Name>
    <File_Description>ASIRAS Processor configuration file: Processor switches and
tunable constants for high altitude interferometric (HAM-SARin) and low altitude (LAM-SAR)
modes</File_Description>
    <Notes>Version 13 makes de-sampling parameter Raw_Echo_Average_Factor obsolete
(though not removed and still ingested by processor. If non unity the processor resets to unity
if file de-sampling if n\
ot indicated in ASIRAS measurement data file name).
    Version 15: Added LAM-A Low sample rate </Notes>
    AS_OPER_PCONF_____20070401T000000_20070501T999999_0001.XML : 2007 campaign
specific
  <Mission_Code>AS</Mission_Code>
  <File_Class>OPER</File_Class>
  <File_Type>PCONF_____</File_Type>
  <File_Version>0001</File_Version>
  <Source>
    <System>name of the system</System>
    <Creator>Robert Cullen</Creator>
    <Creator_Version>01.00</Creator_Version>
    <Creation_Date>2007-09-04T09:34:00</Creation_Date>
  </Source>
  </Fixed_Header>
  <Variable_Header>
    <MPH></MPH>
    <SPH></SPH>
  </Variable_Header>
</Processor_Configuration_Header>
  <Common>
    <Alternate_Const_File>
      <Override>No</Override>
      <Path/>
    </Alternate_Const_File>
    <SARIN_Contingency>
      <Degraded>False</Degraded>
      <Master_Channel>1</Master_Channel>
    </SARIN_Contingency>
    <Roll_Angle_Multiplier>
      <Description>Convention used for angle rotation : clockwise (-1.0) or
anticlockwise (+1.0) rotation</Description>
      <Value>+1.0</Value>
    </Roll_Angle_Multiplier>
    <Pitch_Angle_Multiplier>
      <Description>Convention used for angle rotation : clockwise (-1.0) or
anticlockwise (+1.0) rotation</Description>
      <Value>+1.0</Value>
    </Pitch_Angle_Multiplier>
    <Yaw_Angle_Multiplier>
      <Description>Convention used for angle rotation : clockwise (-1.0) or
anticlockwise (+1.0) rotation</Description>
      <Value>-1.0</Value>
    </Yaw_Angle_Multiplier>
    <Heading_Angle_Multiplier>
      <Description>Convention used for angle rotation : clockwise (-1.0) or
anticlockwise (+1.0) rotation</Description>
      <Value>+1.0</Value>
    </Heading_Angle_Multiplier>
    <Pre_2005_Echo_Count_Multiplier>
      <Description>The echo count multiplier is used to extract echo number from
ASIRAS log files. Prior to 2005 this value was set at 8. Hence all processing of CryoVex 2004
data must use this value of 8. Any Data post 1 Jan 2005 must use the value 1.
Sorry!</Description>
      <Value>8</Value>
    </Pre_2005_Echo_Count_Multiplier>
    <Post_2005_Echo_Count_Multiplier>
```

<Description>The echo count multiplier is used to extract echo number from ASIRAS log files. Prior to 2005 this value was set at 8. Hence all processing of CryoVex 2004 data must use this value of 8. Any Data post 1 Jan 2005 must use the value 1.
Sorry!</Description>

```
<Value>+1</Value>
</Post_2005_Echo_Count_Multiplier>
</Common>
<Preprocessor_SARIn>
  <Generic>
    <Core_Dump>Off</Core_Dump>
    <LogMsgDecimation>1000</LogMsgDecimation>
  </Generic>
  <Preprocessor_SARIn_Specific>
    <Switches>
      <QI_Toggle>
        <Description>Toggle I and Q complex samples</Description>
        <Value>Off</Value>
      </QI_Toggle>
      <Skip_Echoes>
        <Value>0</Value>
      </Skip_Echoes>
    </Switches>
    <Tunable_Constants>
      <Height_Trk_Store_Size>
        <Description>Initial store size for height tracking
information</Description>
        <Value unit="Elements">2000</Value>
      </Height_Trk_Store_Size>
      <AGC_Trk_Store_Size>
        <Description>Initial store size for AGC tracking
information</Description>
        <Value unit="Elements">1000</Value>
      </AGC_Trk_Store_Size>
      <Relative_Echo_Num_Start>
        <Description>Measurement echo start number w.r.t. ASIRAS
log file</Description>
        <Value unit="Elements">0</Value>
      </Relative_Echo_Num_Start>
      <Compact_MicroSec_Size>
        <Description>Mission CFI size for</Description>
        <Value>21</Value>
      </Compact_MicroSec_Size>
      <Log_Total_Pulses_Label>
        <Value>Total Number of Pulses: </Value>
      </Log_Total_Pulses_Label>
      <Relative_Start_Time_Label>
        <Value>RelTime started, RelTime [s]: </Value>
      </Relative_Start_Time_Label>
      <GPS_Time_Tag_Label>
        <Value>GPS Time Tag: UTC </Value>
      </GPS_Time_Tag_Label>
      <AGC_Loop_Label>
        <Value>Att set to:</Value>
      </AGC_Loop_Label>
      <Height_Loop_Label>
        <Value>Initial PRT Value</Value>
        <Description>Initial tracker delay time</Description>
      </Height_Loop_Label>
      <Height_Trk_Loop_Label>
        <Value>PRT Counter:</Value>
        <Description>Manual tracker delay time</Description>
      </Height_Trk_Loop_Label>
      <Counter_Label>
        <Value>Counter:</Value>
      </Counter_Label>
      <Raw_Echo_Average_Factor>
        <Value>1</Value>
        <Description>Averaging factor of time domain waveforms.
Mainly used to reduce IAM data volume</Description>
        <Note>Parameter is obsolete from version 3.04
onwards</Note>
      </Raw_Echo_Average_Factor>
```



```
<Acquisition_Delay>
  <Value unit="s">1.0</Value>
  <Description>Flag first x seconds of raw data as
acquisition data</Description>
</Acquisition_Delay>
</Tunable_Constants>
<Breakpoint_Files>
  <BKPSINPASP>Off</BKPSINPASP>
  <BKPSINPNAV>Off</BKPSINPNAV>
  <BKPSINPMEA>Off</BKPSINPMEA>
  <BKPSINPLOG>Off</BKPSINPLOG>
  <BKPSINPF1_>Off</BKPSINPF1_>
  <BKPSINPGPS>On</BKPSINPGPS>
  <BKPSINPSTV>Off</BKPSINPSTV>
  <BKPSINPATT>Off</BKPSINPATT>
  <BKPSINPSUS>Off</BKPSINPSUS>
  <BKPSINPP09>Off</BKPSINPP09>
  <BKPSINPP10>Off</BKPSINPP10>
  <BKPSINPP11>Off</BKPSINPP11>
  <BKPSINPP12>Off</BKPSINPP12>
  <BKPSINPP13>Off</BKPSINPP13>
  <BKPSINPP14>Off</BKPSINPP14>
  <BKPSINPP15>Off</BKPSINPP15>
  <BKPSINPP16>Off</BKPSINPP16>
  <BKPSINPP17>Off</BKPSINPP17>
  <BKPSINPP18>Off</BKPSINPP18>
  <BKPSINPP19>Off</BKPSINPP19>
</Breakpoint_Files>
  </Preprocessor_SARIn_Specific>
</Preprocessor_SARIn>
<Preprocessor_LAM>
  <Generic>
    <Core_Dump>Of</Core_Dump>
    <LogMsgDecimation>1000</LogMsgDecimation>
  </Generic>
  <Preprocessor_LAM_Specific>
    <Switches>
      <QI_Toggle>
        <Description>Toggle I and Q complex samples</Description>
        <Value>Off</Value>
      </QI_Toggle>
      <Skip_Echoes>
        <Value>0</Value>
      </Skip_Echoes>
    </Switches>
    <Tunable_Constants>
      <Height_Trk_Store_Size>
        <Description>Initial store size for height tracking
information</Description>
        <Value unit="Elements">1</Value>
      </Height_Trk_Store_Size>
      <AGC_Trk_Store_Size>
        <Description>Initial store size for AGC tracking
information</Description>
        <Value unit="Elements">1000</Value>
      </AGC_Trk_Store_Size>
      <Relative_Echo_Num_Start>
        <Description>Measurement echo start number w.r.t. ASIRAS
log file</Description>
        <Value unit="Elements">0</Value>
      </Relative_Echo_Num_Start>
      <Compact_MicroSec_Size>
        <Description>Mission CFI size for</Description>
        <Value>21</Value>
      </Compact_MicroSec_Size>
      <Log_Total_Pulses_Label>
        <Value>Total Number of Pulses: </Value>
      </Log_Total_Pulses_Label>
      <Relative_Start_Time_Label>
        <Value>RelTime started, RelTime [s]: </Value>
      </Relative_Start_Time_Label>
      <GPS_Time_Tag_Label>
        <Value>GPS Time Tag: UTC </Value>
```

```
</GPS_Time_Tag_Label>
<AGC_Loop_Label>
  <Value>Att set to:</Value>
</AGC_Loop_Label>
<Height_Loop_Label>
  <Value>Initial PRT Value</Value>
  <Description>Initial tracker delay time</Description>

</Height_Loop_Label>
<Height_Trk_Loop_Label>
  <Value>PRT Counter:</Value>
  <Description>Manual tracker delay time</Description>
</Height_Trk_Loop_Label>
<Counter_Label>
  <Value>Counter:</Value>
</Counter_Label>
<LAM_Freq_Offset_Label>
  <Value>F306</Value>
</LAM_Freq_Offset_Label>
<Raw_Echo_Average_Factor>
  <Value>1</Value>
  <Description>Averaging factor of time domain waveforms.
Mainly used to reduce LAM data volume</Description>
  <Note>Parameter is obsolete from version 3.04
onwards</Note>
</Raw_Echo_Average_Factor>
<Acquisition_Delay>
  <Value unit="S">1.0</Value>
  <Description>Flag first x seconds of raw data as
acquisition data</Description>
</Acquisition_Delay>
</Tunable_Constants>
<Breakpoint_Files>
  <BKPLAMPASL>Off</BKPLAMPASL>
  <BKPLAMPNAV>Off</BKPLAMPNAV>
  <BKPLAMPMEA>Off</BKPLAMPMEA>
  <BKPLAMPLOG>Off</BKPLAMPLOG>
  <BKPLAMPF1_>Off</BKPLAMPF1_>
  <BKPLAMPGPS>Off</BKPLAMPGPS>
  <BKPLAMPSTV>Off</BKPLAMPSTV>
  <BKPLAMPATT>Off</BKPLAMPATT>
  <BKPLAMPSUS>On</BKPLAMPSUS>
  <BKPLAMPP09>Off</BKPLAMPP09>
  <BKPLAMPP10>Off</BKPLAMPP10>
  <BKPLAMPP11>Off</BKPLAMPP11>
  <BKPLAMPP12>Off</BKPLAMPP12>
  <BKPLAMPP13>Off</BKPLAMPP13>
  <BKPLAMPP14>Off</BKPLAMPP14>
  <BKPLAMPP15>Off</BKPLAMPP15>
  <BKPLAMPP16>Off</BKPLAMPP16>
  <BKPLAMPP17>Off</BKPLAMPP17>
  <BKPLAMPP18>Off</BKPLAMPP18>
  <BKPLAMPP19>Off</BKPLAMPP19>
</Breakpoint_Files>
</Preprocessor_LAM_Specific>
</Preprocessor_LAM>
<Preprocessor_LAMA>
  <Generic>
    <Core_Dump>Of</Core_Dump>
    <LogMsgDecimation>1000</LogMsgDecimation>
  </Generic>
  <Preprocessor_LAMA_Specific>
    <Switches>
      <QI_Toggle>
        <Description>Toggle I and Q complex samples</Description>
        <Value>Off</Value>
      </QI_Toggle>
      <Skip_Echoes>
        <Value>0</Value>
      </Skip_Echoes>
    </Switches>
  </Preprocessor_LAMA_Specific>
</Preprocessor_LAMA>
<Tunable_Constants>
  <Height_Trk_Store_Size>
```



```
information</Description>
    <Description>Initial store size for height tracking
    <Value unit="Elements">1</Value>
</Height_Trk_Store_Size>
<AGC_Trk_Store_Size>
    <Description>Initial store size for AGC tracking
information</Description>
    <Value unit="Elements">1000</Value>
</AGC_Trk_Store_Size>
<Relative_Echo_Num_Start>
    <Description>Measurement echo start number w.r.t. ASIRAS
log file</Description>
    <Value unit="Elements">0</Value>
</Relative_Echo_Num_Start>
<Compact_MicroSec_Size>
    <Description>Mission CFI size for</Description>
    <Value>21</Value>
</Compact_MicroSec_Size>
<Log_Total_Pulses_Label>
    <Value>Total Number of Pulses: </Value>
</Log_Total_Pulses_Label>
<Relative_Start_Time_Label>
    <Value>RelTime started, RelTime [s]: </Value>
</Relative_Start_Time_Label>
<GPS_Time_Tag_Label>
    <Value>GPS Time Tag: UTC </Value>
</GPS_Time_Tag_Label>
<AGC_Loop_Label>
    <Value>Att set to:</Value>
</AGC_Loop_Label>
<Height_Loop_Label>
    <Value>Initial PRT Value</Value>
    <Description>Initial tracker delay time</Description>
</Height_Loop_Label>
<Height_Trk_Loop_Label>
    <Value>PRT Counter:</Value>
    <Description>Manual tracker delay time</Description>
</Height_Trk_Loop_Label>
<Counter_Label>
    <Value>Counter:</Value>
</Counter_Label>
<LAM_Freq_Offset_Label>
    <Value>F306</Value>
</LAM_Freq_Offset_Label>
<Raw_Echo_Average_Factor>
    <Value>1</Value>
    <Description>Averaging factor of time domain waveforms.
Mainly used to reduce LAM data volume</Description>
    <Note>Parameter is obsolete from version 3.04
onwards</Note>
</Raw_Echo_Average_Factor>
<Acquisition_Delay>
    <Value unit="S">1.0</Value>
    <Description>Flag first x seconds of raw data as
acquisition data</Description>
    </Acquisition_Delay>
</Tunable_Constants>
<Breakpoint_Files>
    <BKPLAAPASL>Off</BKPLAAPASL>
    <BKPLAAPNAV>Off</BKPLAAPNAV>
    <BKPLAAPMEA>Off</BKPLAAPMEA>
    <BKPLAAPLOG>Off</BKPLAAPLOG>
    <BKPLAAPF1_>Off</BKPLAAPF1_>
    <BKPLAAPGPS>Off</BKPLAAPGPS>
    <BKPLAAPSTV>Off</BKPLAAPSTV>
    <BKPLAAPATT>Off</BKPLAAPATT>
    <BKPLAAPSUS>On</BKPLAAPSUS>
    <BKPLAAPP09>Off</BKPLAAPP09>
    <BKPLAAPP10>Off</BKPLAAPP10>
    <BKPLAAPP11>Off</BKPLAAPP11>
    <BKPLAAPP12>Off</BKPLAAPP12>
    <BKPLAAPP13>Off</BKPLAAPP13>
```

```

        <BKPLAAPP14>Off</BKPLAAPP14>
        <BKPLAAPP15>Off</BKPLAAPP15>
        <BKPLAAPP16>Off</BKPLAAPP16>
        <BKPLAAPP17>Off</BKPLAAPP17>
        <BKPLAAPP18>Off</BKPLAAPP18>
        <BKPLAAPP19>Off</BKPLAAPP19>
    </Breakpoint_Files>
  </Preprocessor_LAMA_Specific>
</Preprocessor_LAMA>
<SARin>
  <Generic>
    <Core_Dump>Off</Core_Dump>
    <LogMsgDecimation>500</LogMsgDecimation>
  </Generic>
  <SARin_Specific>
    <Switches>
      <Apply_Fine_Slant_Range>
        <Description>Apply the fine slant range
correction</Description>
        <Value>On</Value>
      </Apply_Fine_Slant_Range>
      <Apply_Coarse_Slant_Range>
        <Description>Apply the integer coarse slant range
correction</Description>
        <Value>On</Value>
      </Apply_Coarse_Slant_Range>
      <Apply_Doppler_Range>
        <Description>Apply the Doppler range
correction</Description>
        <Value>On</Value>
      </Apply_Doppler_Range>
      <Force_Approx_Former>
        <Description></Description>
        <Value>On</Value>
      </Force_Approx_Former>
      <Force_Exact_Former>
        <Description></Description>
        <Value>Off</Value>
      </Force_Exact_Former>
      <Beam_Weighting>
        <Description>Fit determined from Doppler beam stack
power</Description>
        <Value>On</Value>
      </Beam_Weighting>
      <Beam_Weighting_Method>
        <Description>Method of Doppler beam stack weighting. A -
Uniform, B - Gaussian</Description>
        <Value>B</Value>
      </Beam_Weighting_Method>
      <Apply_Beam_Weights>
        <Description>Apply Doppler beam weighting to
stack</Description>
        <Value>Off</Value>
      </Apply_Beam_Weights>
      <Threshold_Beam_Power>
        <Description></Description>
        <Value>On</Value>
      </Threshold_Beam_Power>
      <Use_Internal_Noise_Power>
        <Description>Noise floor determined internal to
specialised processor (On). Otherwise on-board value used (Off)</Description>
        <Value>On</Value>
      </Use_Internal_Noise_Power>
      <QI_Toggle>
        <Description>Toggle I and Q complex samples</Description>
        <Value>Off</Value>
      </QI_Toggle>
      <Fix_Processed_SPs>
        <Description>The number of FBR records to process (-1
signifies all records)</Description>
        <Value>-1</Value>
      </Fix_Processed_SPs>
    </Switches>
  </SARin_Specific>
</SARin>
  <Fix_Breakpoint_SP_Start>

```



```
<Description>The first FBR record to output (-1 signifies
all)</Description>
    <Value>-1</Value>
</Fix_Breakpoint_SP_Start>
<Fix_Breakpoint_SP_Stop>
    <Description>The last FBR record to output (-1 signifies
all)</Description>
    <Value>-1</Value>
</Fix_Breakpoint_SP_Stop>
<Anti_Alias_Power_Echoes>
    <Description>NO-LONGER USED: Switch to turn on/off anti
aliased power echo determination</Description>
    <Value>Off</Value>
</Anti_Alias_Power_Echoes>
<Apply_Azimuth_Cal_Correction>
    <Description>Switch on/off application of azimuth impulse
resonse correction</Description>
    <Value>Off</Value>
</Apply_Azimuth_Cal_Correction>
<Apply_P_A_Cal_Correction>
    <Description>Switch on/off application of phase difference
and amplitude w.r.t frequency correction</Description>
    <Value>Off</Value>
</Apply_P_A_Cal_Correction>
<Steer_Beams>
    <Value>On</Value>
</Steer_Beams>
<Remove_I_Q_Bias>
    <Value>On</Value>
</Remove_I_Q_Bias>
<Range_Compression>
    <Value>On</Value>
</Range_Compression>
<Beam_Formation>
    <Value>On</Value>
</Beam_Formation>
<Apply_Inst_Delay_Correction>
    <Value>Off</Value>
</Apply_Inst_Delay_Correction>
<Apply_Int_Phase_Diff_Corr>
    <Value>Off</Value>
</Apply_Int_Phase_Diff_Corr>
<Skip_L1_Records>
    <Value>0</Value>
</Skip_L1_Records>
<Reverse_Phase_Diff>
    <Value>Off</Value>
</Reverse_Phase_Diff>
<Reverse_Baseline>
    <Value>Off</Value>
</Reverse_Baseline>
<Interpolate_Orientation>
    <Value>Off</Value>
</Interpolate_Orientation>
<Apply_Azimuth_Hamming>
    <Value>Off</Value>
    <Description>Apply a hamming window to time domain burst
prior to azimuth FFT</Description>
</Apply_Azimuth_Hamming>
<Apply_Range_Hamming>
    <Value>Off</Value>
    <Description>Apply a hamming window to time domain beams
prior to range FFT</Description>
</Apply_Range_Hamming>
<Apply_Roll_Correction>
    <Value>On</Value>
    <Description>Apply phase difference correction to
compensate for the roll of aircraft</Description>
</Apply_Roll_Correction>
<Window_L1b_Echo>
    <Value>Off</Value>
    <Description>Select a set of level 1b waveform samples
about re-track echo point</Description>
```



```
</Window_L1b_Echo>
<OCOG_Remove_Noise_Floor>
  <Value>Off</Value>
  <Description>Remove noise floor from echoes during OCOG
re-tracking</Description>
</OCOG_Remove_Noise_Floor>
<Retracker_Type>
  <Value>OCOG</Value>
  <Description>Retracker types (OCOG), (Threshold), (Model_1
not implemented)</Description>
</Retracker_Type>
</Switches>
<Tunable_Constants>
  <Stack_Size>
    <Description>Maximum size of the stack for SARin
mode</Description>
    <Value unit="Doppler beams">300</Value>
    <Min_Value>40</Min_Value>
    <Max_Value>150</Max_Value>
  </Stack_Size>
  <Burst_Store>
    <Description>Size of Level 1 Source packet store for SARin
mode</Description>
    <Value unit="Level 1 Source packets">600</Value>
    <Min_Value>100</Min_Value>
    <Max_Value>500</Max_Value>
  </Burst_Store>
  <Centre_Burst_Loc>
    <Description>Burst processing Location in Source packet
buffer for SARin mode (Must be less than 0 and greater than burst store size)</Description>
    <Value unit="Level 1 Source packet">300</Value>
    <Min_Value>70</Min_Value>
    <Max_Value>350</Max_Value>
  </Centre_Burst_Loc>
  <Beam_Form_Threshold>
    <Description>Change in elevation between surface samples
used to switch between approximate and exact beam formation methods</Description>
    <Value unit="Metres">3.0000000000000000E+02</Value>
    <Min_Value>0.0</Min_Value>
    <Max_Value>1.E3</Max_Value>
  </Beam_Form_Threshold>
  <Initial_Angle>
    <Description>Initial angle to generate surface
samples</Description>
    <Value unit="Radians">+0.0</Value>
    <Min_Value>-0.001</Min_Value>
    <Max_Value>+0.001</Max_Value>
  </Initial_Angle>
  <Multi_Look_Angle_Start>
    <Description>Threshold angle to trigger multi-looking of
beams directed at any surface sample</Description>
    <Value unit="Deg">6.0</Value>
    <Min_Value>5.E-1</Min_Value>
    <Max_Value>7.E-1</Max_Value>
  </Multi_Look_Angle_Start>
  <Multi_Look_Angle_Stop>
    <Description>Threshold angle to trigger gathering of beams
directed at any surface sample</Description>
    <Value unit="Deg">6.0</Value>
    <Min_Value>5.E-1</Min_Value>
    <Max_Value>7.E-1</Max_Value>
  </Multi_Look_Angle_Stop>
  <Num_Sub_Stack_Beams>
    <Description>Number of Doppler beams to sub-stack in
generation of noise floor power</Description>
    <Value unit="Doppler beams">1</Value>
    <Min_Value>1</Min_Value>
    <Max_Value>10</Max_Value>
  </Num_Sub_Stack_Beams>
  <Noise_Range_Start>
    <Description>Range bin for start of noise floor power
computation</Description>
    <Value unit="Range bin">14</Value>
```



```
<Min_Value>14</Min_Value>
<Max_Value>25</Max_Value>
</Noise_Range_Start>
<Noise_Range_Stop>
  <Description>Range bin for end of noise floor power
computation</Description>
  <Value>25</Value>
  <Min_Value>14</Min_Value>
  <Max_Value>25</Max_Value>
</Noise_Range_Stop>
<Sigma_Threshold>
  <Description>Multiplier of the standard deviation for
noise thresholding</Description>
  <Value>3</Value>
  <Min_Value>1</Min_Value>
  <Max_Value>6</Max_Value>
</Sigma_Threshold>
<Power_Mult_Ch_1>
  <Description>Spare power multiplier for Channel
1</Description>
  <Value unit="unitless">1.0</Value>
  <Min_Value>1.E-30</Min_Value>
  <Max_Value>1.E30</Max_Value>
</Power_Mult_Ch_1>
<Power_Mult_Ch_2>
  <Description>Spare power multiplier for Channel
2</Description>
  <Value unit="unitless">1.0</Value>
  <Min_Value>1.E-30</Min_Value>
  <Max_Value>1.E30</Max_Value>
</Power_Mult_Ch_2>
<Noise_Power_Mult_Ch_1>
  <Description>Noise power multiplier for Channel
1</Description>
  <Value unit="unitless">1.0</Value>
  <Min_Value>1.E-30</Min_Value>
  <Max_Value>1.E30</Max_Value>
</Noise_Power_Mult_Ch_1>
<Noise_Power_Mult_Ch_2>
  <Description>Noise power multiplier for Channel
2</Description>
  <Value unit="unitless">1.0</Value>
  <Min_Value>1.E-30</Min_Value>
  <Max_Value>1.E30</Max_Value>
</Noise_Power_Mult_Ch_2>
<Echoes_Per_Burst_1_Hz>
  <Description>Number of echoes per burst in 1Hz pulse
limited echo generation</Description>
  <Value unit="Echoes">64</Value>
  <Min_Value>1</Min_Value>
  <Max_Value>64</Max_Value>
</Echoes_Per_Burst_1_Hz>
<L1_HRB>
  <Description>Number of SAR/SARIn FBR high rate blocks
(HRB) per record</Description>
  <Value unit="HRB">20</Value>
  <Min_Value>20</Min_Value>
  <Max_Value>20</Max_Value>
</L1_HRB>
<L1B_Blocks_Per_Record>
  <Description>Number of SAR/SARIn FBR samples per
record</Description>
  <Value unit="Samples">20</Value>
  <Min_Value>20</Min_Value>
  <Max_Value>20</Max_Value>
</L1B_Blocks_Per_Record>
<L1b_Max_Product_Power>
  <Description>Maximum value of L1b processed power
echo</Description>
  <Value unit="Counts">65535.0</Value>
  <Min_Value>65535.0</Min_Value>
  <Max_Value>65535.0</Max_Value>
</L1b_Max_Product_Power>
```



```
<Datation_Gap_Restart>
  <Description>Time lapse between samples used to re-start
SARIN processing</Description>
  <Value unit="Seconds">1.0</Value>
  <Min_Value>1.E-3</Min_Value>
  <Max_Value>10.0</Max_Value>
</Datation_Gap_Restart>
<OCOG_Start>
  <Description>Start range bin for OCOG calculation (0=first
range bin)</Description>
  <Value unit="Range bin">10</Value>
</OCOG_Start>
<OCOG_Stop>
  <Description>End range bin for OCOG calculation (0=first
range bin)</Description>
  <Value unit="Range bin">245</Value>
</OCOG_Stop>
<OCOG_Retrack_Threshold>
  <Description>Retrack threshold min=0,
max=1.0</Description>
  <Value>0.8</Value>
</OCOG_Retrack_Threshold>
<OCOG_Default_Range>
  <Description>If the re-tracker fails the out range ins
fixed to this value</Description>
  <Value unit="Meters">-99999.999</Value>
</OCOG_Default_Range>
<OCOG_Upper_Boundary>
  <Value unit="">230.0</Value>
  <Description></Description>
</OCOG_Upper_Boundary>
<OCOG_Lower_Boundary>
  <Description></Description>
  <Value unit="">25.0</Value>
</OCOG_Lower_Boundary>
<OCOG_Echo_Width_Threshold>
  <Description>Echo width threshold that will trigger flag
in waveform group</Description>
  <Value unit="bin">11.0</Value>
</OCOG_Echo_Width_Threshold>
<OCOG_Noise_Floor_Start>
  <Description>If noise floor is to be removed from echoes
during ocoq re-tracking then what is the start range bin for this computation</Description>
  <Value unit="bin">5</Value>
</OCOG_Noise_Floor_Start>
<OCOG_Noise_Floor_Stop>
  <Description>If noise floor is to be removed from echoes
during ocoq re-tracking then what is the stop range bin for this computation</Description>
  <Value unit="bin">10</Value>
</OCOG_Noise_Floor_Stop>
<OCOG_Noise_Floor_Sigma_Factor>
  <Description>If noise floor is to be removed the threshold
level is x standard deviations above the mean power</Description>
  <Value unit="standard deviations">6.0</Value>
</OCOG_Noise_Floor_Sigma_Factor>
<IQ_Bias_Remove_Min>
  <Description>The minimum time domain echo sample number to
start calculation of I and Q waveform biases</Description>
  <Value unit="Sample">180</Value>
</IQ_Bias_Remove_Min>
<IQ_Bias_Remove_Max>
  <Description>The maximum time domain echo sample number
to end calculation of I and Q waveform biases</Description>
  <Value unit="Sample">220</Value>
</IQ_Bias_Remove_Max>
<Yaw_Threshold>
  <Value unit="Deg">1.0</Value>
  <Description>Threshold to trigger MCD flag if angle is
exceeded</Description>
</Yaw_Threshold>
<Roll_Threshold>
  <Value unit="Deg">1.0</Value>
```

```
<Description>Threshold to trigger MCD flag if angle is
exceeded</Description>
</Roll_Threshold>
<Pitch_Threshold>
  <Value unit="Deg">1.0</Value>
  <Description>Threshold to trigger MCD flag if angle is
exceeded</Description>
</Pitch_Threshold>
<Yaw_SD_Threshold>
  <Value unit="Deg">0.3</Value>
  <Description>Standard deviation threshold to trigger MCD
flag if angle is exceeded</Description>
</Yaw_SD_Threshold>
<Roll_SD_Threshold>
  <Value unit="Deg">0.3</Value>
  <Description>Standard deviation threshold to trigger MCD
flag if angle is exceeded</Description>
</Roll_SD_Threshold>
<Pitch_SD_Threshold>
  <Value unit="Deg">0.3</Value>
  <Description>Standard deviation threshold to trigger MCD
flag if angle is exceeded</Description>
</Pitch_SD_Threshold>
<L1b_Wfm_Length>
  <Value unit="Range bin">256</Value>
  <Description>The number of range bins stored in level 1b
file</Description>
</L1b_Wfm_Length>
<Max_Tracker_Var_Over_Stack>
  <Value unit="Range bin">50</Value>
  <Description>if tracker varies significantly over stack
the stack needs to be rejected. This parameter is used to determine the cut off point at which
the tracker variation is such it could cause excessive use of memory</Description>
</Max_Tracker_Var_Over_Stack>
</Tunable_Constants>
<Breakpoint_Files>
  <BKPSINSOAT>Off</BKPSINSOAT>
  <BKPSINSUS>On</BKPSINSUS>
  <BKPSINSAEL>Off</BKPSINSAEL>
  <BKPSINSGDF>Off</BKPSINSGDF>
  <BKPSINSCDF>Off</BKPSINSCDF>
  <BKPSINSSSS>Off</BKPSINSSSS>
  <BKPSINSPBF>Off</BKPSINSPBF>
  <BKPSINSSBR>Off</BKPSINSSBR>
  <BKPSINSPBS>Off</BKPSINSPBS>
  <BKPSINSABF>Off</BKPSINSABF>
  <BKPSINSAPS>Off</BKPSINSAPS>
  <BKPSINSLES>Off</BKPSINSLES>
  <BKPSINSUPT>Off</BKPSINSUPT>
  <BKPSINSRAC>Off</BKPSINSRAC>
  <BKPSINSSLA>Off</BKPSINSSLA>
  <BKPSINSRBU>Off</BKPSINSRBU>
  <BKPSINSDPW>Off</BKPSINSDPW>
  <BKPSINSFBO>Off</BKPSINSFBO>
  <BKPSINSF1B>Off</BKPSINSF1B>
  <BKPSINSLOG>Off</BKPSINSLOG>
  <BKPSINSINT>Off</BKPSINSINT>
  <BKPSINSBED>Off</BKPSINSBED>
  <BKPSINSHDO>Off</BKPSINSHDO>
  <BKPSINSF1_>Off</BKPSINSF1_>
  <BKPSINSFIF>Off</BKPSINSFIF>
  <BKPSINSFAT>Off</BKPSINSFAT>
  <BKPSINSMUL>Off</BKPSINSMUL>
  <BKPSINSJP1>Off</BKPSINSJP1>
  <BKPSINSJP2>Off</BKPSINSJP2>
  <BKPSINSFFT>Off</BKPSINSFFT>
</Breakpoint_Files>
</SARin_Specific>
</SARin>
<LAM>
  <Generic>
    <Core_Dump>Off</Core_Dump>
    <LogMsgDecimation>50</LogMsgDecimation>
```

```

    </Generic>
    <LAM_Specific>
      <Switches>
        <Apply_Fine_Slant_Range>
          <Description>Apply the fine slant range
          <Value>On</Value>
        </Apply_Fine_Slant_Range>
        <Apply_Coarse_Slant_Range>
          <Description>Apply the integer coarse slant range
          <Value>On</Value>
        </Apply_Coarse_Slant_Range>
        <Apply_Doppler_Range>
          <Description>Apply the Doppler range
          <Value>On</Value>
        </Apply_Doppler_Range>
        <Force_Approx_Former>
          <Description></Description>
          <Value>On</Value>
        </Force_Approx_Former>
        <Force_Exact_Former>
          <Description></Description>
          <Value>Off</Value>
        </Force_Exact_Former>
        <Beam_Weighting>
          <Description>Fit determined from Doppler beam stack
          <Value>On</Value>
        </Beam_Weighting>
        <Beam_Weighting_Method>
          <Description>Method of Doppler beam stack weighting. A -
          Uniform, B - Gaussian</Description>
          <Value>B</Value>
        </Beam_Weighting_Method>
        <Apply_Beam_Weights>
          <Description>Apply Doppler beam weight stack
          <Value>Off</Value>
        </Apply_Beam_Weights>
        <Threshold_Beam_Power>
          <Description></Description>
          <Value>On</Value>
        </Threshold_Beam_Power>
        <Use_Internal_Noise_Power>
          <Description>Noise floor determined internal to
          specialised processor (On). Otherwise on-board value used (Off)</Description>
          <Value>On</Value>
        </Use_Internal_Noise_Power>
        <QI_Toggle>
          <Description>Toggle I and Q complex samples</Description>
          <Value>Off</Value>
        </QI_Toggle>
        <Fix_Processed_SPs>
          <Description>The number of FBR records to process (-1
          signifies all records)</Description>
          <Value>-1</Value>
        </Fix_Processed_SPs>
        <Fix_Breakpoint_SP_Start>
          <Description>The first FBR record to output (-1 signifies
          all)</Description>
          <Value>-1</Value>
        </Fix_Breakpoint_SP_Start>
        <Fix_Breakpoint_SP_Stop>
          <Description>The last FBR record to output (-1 signifies
          all)</Description>
          <Value>-1</Value>
        </Fix_Breakpoint_SP_Stop>
        <Anti_Alias_Power_Echoes>
          <Description>NO LONGER USED:Switch to turn on/off anti
          aliased power echo determination</Description>
          <Value>Off</Value>

```



```
</Anti_Alias_Power_Echoes>
<Apply_Azimuth_Cal_Correction>
  <Description>Switch on/off application of azimuth impulse
resonse correction</Description>
  <Value>Off</Value>
</Apply_Azimuth_Cal_Correction>
<Apply_P_A_Cal_Correction>
  <Description>Switch on/off application of phase difference
and amplitude w.r.t frequency correction</Description>
  <Value>Off</Value>
</Apply_P_A_Cal_Correction>
<Steer_Beams>
  <Value>On</Value>
</Steer_Beams>
<Remove_I_Q_Bias>
  <Value>On</Value>
</Remove_I_Q_Bias>
<Range_Compression>
  <Value>On</Value>
</Range_Compression>
<Beam_Formation>
  <Value>On</Value>
</Beam_Formation>
<Apply_Inst_Delay_Correction>
  <Value>Off</Value>
</Apply_Inst_Delay_Correction>
<Apply_Int_Phase_Diff_Corr>
  <Value>Off</Value>
</Apply_Int_Phase_Diff_Corr>
<Skip_L1_Records>
  <Value>0</Value>
</Skip_L1_Records>
<Reverse_Phase_Diff>
  <Value>Off</Value>
</Reverse_Phase_Diff>
<Reverse_Baseline>
  <Value>Off</Value>
</Reverse_Baseline>
<Interpolate_Orientation>
  <Value>Off</Value>
</Interpolate_Orientation>
<Apply_Azimuth_Hamming>
  <Value>On</Value>
  <Description>Apply a hamming window to time domain burst
prior to azimuth FFT</Description>
</Apply_Azimuth_Hamming>
<Apply_Range_Hamming>
  <Value>On</Value>
  <Description>Apply a hamming window to time domain beams
prior to range FFT</Description>
</Apply_Range_Hamming>
<Apply_Roll_Correction>
  <Value>Off</Value>
  <Description>Apply phase difference correction to
compensate for the roll of aircraft</Description>
</Apply_Roll_Correction>
<Window_L1b_Echo>
  <Value>Off</Value>
  <Description>Select a set of level 1b waveform samples
about re-track echo point</Description>
</Window_L1b_Echo>
<OCOG_Remove_Noise_Floor>
  <Value>On</Value>
  <Description>Remove noise floor from echoes during OCOG
re-tracking</Description>
</OCOG_Remove_Noise_Floor>
<Retracker_Type>
  <Value>OCOG</Value>
  <Description>Retracker types (OCOG), (Threshold), (Model_1
not implemented)</Description>
</Retracker_Type>
</Switches>
<Tunable_Constants>
```

```
<Stack_Size>
  <Description>Maximum size of the stack for SARIn
mode</Description>
  <Value unit="Doppler beams">300</Value>
  <Min_Value>40</Min_Value>
  <Max_Value>150</Max_Value>
</Stack_Size>
<Burst_Store>
  <Description>Size of Level 1 Source packet store for SARIn
mode</Description>
  <Value unit="Level 1 Source packets">600</Value>
  <Min_Value>100</Min_Value>
  <Max_Value>500</Max_Value>
</Burst_Store>
<Centre_Burst_Loc>
  <Description>Burst processing Location in Source packet
buffer for SARIn mode (Must be less than 0 and greater than burst store size)</Description>
  <Value unit="Level 1 Source packet">300</Value>
  <Min_Value>70</Min_Value>
  <Max_Value>350</Max_Value>
</Centre_Burst_Loc>
<Beam_Form_Threshold>
  <Description>Change in elevation between surface samples
used to switch between approximate and exact beam formation methods</Description>
  <Value unit="Metres">3.0000000000000000E+02</Value>
  <Min_Value>0.0</Min_Value>
  <Max_Value>1.E3</Max_Value>
</Beam_Form_Threshold>
<Initial_Angle>
  <Description>Initial angle to generate surface
samples</Description>
  <Value unit="Radians">+0.0</Value>
  <Min_Value>-0.001</Min_Value>
  <Max_Value>+0.001</Max_Value>
</Initial_Angle>
<Multi_Look_Angle_Start>
  <Description>Threshold angle to trigger multi-looking of
beams directed at any surface sample</Description>
  <Value unit="Deg">6.0</Value>
  <Min_Value>5.E-1</Min_Value>
  <Max_Value>7.E-1</Max_Value>
</Multi_Look_Angle_Start>
<Multi_Look_Angle_Stop>
  <Description>Threshold angle to trigger gathering of beams
directed at any surface sample</Description>
  <Value unit="Deg">6.0</Value>
  <Min_Value>5.E-1</Min_Value>
  <Max_Value>7.E-1</Max_Value>
</Multi_Look_Angle_Stop>
<Num_Sub_Stack_Beams>
  <Description>Number of Doppler beams to sub-stack in
generation of noise floor power</Description>
  <Value unit="Doppler beams">1</Value>
  <Min_Value>1</Min_Value>
  <Max_Value>10</Max_Value>
</Num_Sub_Stack_Beams>
<Noise_Range_Start>
  <Description>Range bin for start of noise floor power
computation</Description>
  <Value unit="Range bin">14</Value>
  <Min_Value>14</Min_Value>
  <Max_Value>25</Max_Value>
</Noise_Range_Start>
<Noise_Range_Stop>
  <Description>Range bin for end of noise floor power
computation</Description>
  <Value>25</Value>
  <Min_Value>14</Min_Value>
  <Max_Value>25</Max_Value>
</Noise_Range_Stop>
<Sigma_Threshold>
  <Description>Multiplier of the standard deviation for
noise thresholding</Description>
```

```

    <Value>3</Value>
    <Min_Value>1</Min_Value>
    <Max_Value>6</Max_Value>
  </Sigma_Threshold>
  <Power_Mult_Ch_1>
    <Description>Spare power multiplier for Channel
1</Description>
    <Value unit="unitless">1.0</Value>
    <Min_Value>1.E-30</Min_Value>
    <Max_Value>1.E30</Max_Value>
  </Power_Mult_Ch_1>
  <Power_Mult_Ch_2>
    <Description>Spare power multiplier for Channel
2</Description>
    <Value unit="unitless">1.0</Value>
    <Min_Value>1.E-30</Min_Value>
    <Max_Value>1.E30</Max_Value>
  </Power_Mult_Ch_2>
  <Noise_Power_Mult_Ch_1>
    <Description>Noise power multiplier for Channel
1</Description>
    <Value unit="unitless">1.0</Value>
    <Min_Value>1.E-30</Min_Value>
    <Max_Value>1.E30</Max_Value>
  </Noise_Power_Mult_Ch_1>
  <Noise_Power_Mult_Ch_2>
    <Description>Noise power multiplier for Channel
2</Description>
    <Value unit="unitless">1.0</Value>
    <Min_Value>1.E-30</Min_Value>
    <Max_Value>1.E30</Max_Value>
  </Noise_Power_Mult_Ch_2>
  <Echoes_Per_Burst_1_Hz>
    <Description>Number of echoes per burst in 1Hz pulse
limited echo generation</Description>
    <Value unit="Echoes">64</Value>
    <Min_Value>1</Min_Value>
    <Max_Value>64</Max_Value>
  </Echoes_Per_Burst_1_Hz>
  <L1_HRB>
    <Description>Number of SAR/SARIn FBR high rate blocks
(HRB) per record</Description>
    <Value unit="HRB">20</Value>
    <Min_Value>20</Min_Value>
    <Max_Value>20</Max_Value>
  </L1_HRB>
  <L1B_Blocks_Per_Record>
    <Description>Number of SAR/SARIn FBR samples per
record</Description>
    <Value unit="Samples">20</Value>
    <Min_Value>20</Min_Value>
    <Max_Value>20</Max_Value>
  </L1B_Blocks_Per_Record>
  <L1b_Max_Product_Power>
    <Description>Maximum value of L1b processed power
echo</Description>
    <Value unit="Counts">65535.0</Value>
    <Min_Value>65535.0</Min_Value>
    <Max_Value>65535.0</Max_Value>
  </L1b_Max_Product_Power>
  <Datation_Gap_Restart>
    <Description>Time lapse between samples used to re-start
SARIN processing</Description>
    <Value unit="Seconds">1.0</Value>
    <Min_Value>1.E-3</Min_Value>
    <Max_Value>10.0</Max_Value>
  </Datation_Gap_Restart>
  <OCOG_Start>
    <Description>Start range bin for OCOG calculation (0=first
range bin)</Description>
    <Value unit="Range bin">200</Value>
  </OCOG_Start>
  <OCOG_Stop>

```



```
range bin)/<Description>End range bin for OCOG calculation (0=first
range bin)/</Description>
    <Value unit="Range bin">3900</Value>
</OCO_G_Stop>
<OCO_Retrack_Threshold>
    <Description>Retrack threshold min=0,
max=1.0</Description>
    <Value>0.8</Value>
</OCO_Retrack_Threshold>
<OCO_Default_Range>
    <Description>If the re-tracker fails the out range is
fixed to this value</Description>
    <Value unit="Meters">-99999.999</Value>
</OCO_Default_Range>
<OCO_Upper_Boundary>
    <Value unit="">3900</Value>
    <Description></Description>
</OCO_Upper_Boundary>
<OCO_Lower_Boundary>
    <Description></Description>
    <Value unit="">200</Value>
</OCO_Lower_Boundary>
<OCO_Echo_Width_Threshold>
<Description>Echo width threshold that will trigger flag in
waveform group</Description>
    <Value unit="bin">20.0</Value>
</OCO_Echo_Width_Threshold>
<OCO_Noise_Floor_Start>
    <Description>If noise floor is to be removed from echoes
during ocoG re-tracking then what is the start range bin for this computation</Description>
    <Value unit="bin">10</Value>
</OCO_Noise_Floor_Start>
<OCO_Noise_Floor_Stop>
    <Description>If noise floor is to be removed from echoes
during ocoG re-tracking then what is the stop range bin for this computation</Description>
    <Value unit="bin">50</Value>
</OCO_Noise_Floor_Stop>
<OCO_Noise_Floor_Sigma_Factor>
    <Description>If noise floor is to be removed the threshold
level is x standard deviations above the mean power</Description>
    <Value unit="standard deviations">3.0</Value>
</OCO_Noise_Floor_Sigma_Factor>
<IQ_Bias_Remove_Min>
    <Description>The minimum time domain echo sample number to
start calculation of I and Q waveform biases</Description>
    <Value unit="Sample">0</Value>
</IQ_Bias_Remove_Min>
<IQ_Bias_Remove_Max>
    <Description>The maximum time domain echo sample number
to end calculation of I and Q waveform biases</Description>
    <Value unit="Sample">3071</Value>
</IQ_Bias_Remove_Max>
<Yaw_Threshold>
    <Value unit="Deg">1.0</Value>
    <Description>Threshold to trigger MCD flag if angle is
exceeded</Description>
</Yaw_Threshold>
<Roll_Threshold>
    <Value unit="Deg">1.0</Value>
    <Description>Threshold to trigger MCD flag if angle is
exceeded</Description>
</Roll_Threshold>
<Pitch_Threshold>
    <Value unit="Deg">1.0</Value>
    <Description>Threshold to trigger MCD flag if angle is
exceeded</Description>
</Pitch_Threshold>
<Yaw_SD_Threshold>
    <Value unit="Deg">0.3</Value>
    <Description>Standard deviation threshold to trigger MCD
flag if angle is exceeded</Description>
</Yaw_SD_Threshold>
<Roll_SD_Threshold>
```



```
<Value unit="Deg">0.3</Value>
<Description>Standard deviation threshold to trigger MCD
flag if angle is exceeded</Description>
</Roll_SD_Threshold>
<Pitch_SD_Threshold>
<Value unit="Deg">0.3</Value>
<Description>Standard deviation threshold to trigger MCD
flag if angle is exceeded</Description>
</Pitch_SD_Threshold>
<L1b_Wfm_Length>
<Value unit="Range bin">4096</Value>
<Description>The number of range bins stored in level 1b
file</Description>
</L1b_Wfm_Length>
<Max_Tracker_Var_Over_Stack>
<Value unit="Range bin">50</Value>
<Description>if tracker varies significantly over stack
the stack needs to be rejected. This parameter is used to determine the cut off point at which
the tracker variation is such it could cause excessive use of memory</Description>
</Max_Tracker_Var_Over_Stack>
</Tunable_Constants>
<Breakpoint_Files>
<BKPLAMSOAT>Off</BKPLAMSOAT>
<BKPLAMSSUS>On</BKPLAMSSUS>
<BKPLAMSAEL>Off</BKPLAMSAEL>
<BKPLAMSGDF>Off</BKPLAMSGDF>
<BKPLAMSCDF>Off</BKPLAMSCDF>
<BKPLAMSSSS>Off</BKPLAMSSSS>
<BKPLAMSPBF>Off</BKPLAMSPBF>
<BKPLAMSSBR>Off</BKPLAMSSBR>
<BKPLAMSPBS>Off</BKPLAMSPBS>
<BKPLAMSABF>Off</BKPLAMSABF>
<BKPLAMSAPS>Off</BKPLAMSAPS>
<BKPLAMSLER>Off</BKPLAMSLER>
<BKPLAMSUPT>Off</BKPLAMSUPT>
<BKPLAMSRAC>Off</BKPLAMSRAC>
<BKPLAMSSLA>Off</BKPLAMSSLA>
<BKPLAMSRBU>Off</BKPLAMSRBU>
<BKPLAMSDPW>Off</BKPLAMSDPW>
<BKPLAMSFBO>Off</BKPLAMSFBO>
<BKPLAMSF1B>Off</BKPLAMSF1B>
<BKPLAMSLLOG>Off</BKPLAMSLLOG>
<BKPLAMSINT>Off</BKPLAMSINT>
<BKPLAMSBED>Off</BKPLAMSBED>
<BKPLAMSHDO>Off</BKPLAMSHDO>
<BKPLAMSF1_>Off</BKPLAMSF1_>
<BKPLAMSFIF>Off</BKPLAMSFIF>
<BKPLAMSFAT>Off</BKPLAMSFAT>
<BKPLAMSMUL>Off</BKPLAMSMUL>
<BKPLAMJ1>Off</BKPLAMJ1>
<BKPLAMJ2>Off</BKPLAMJ2>
<BKPLAMSFFT>Off</BKPLAMSFFT>
</Breakpoint_Files>
</LAM_Specific>
</LAM>
<LAMA_A>
<Generic>
<Core_Dump>Off</Core_Dump>
<LogMsgDecimation>50</LogMsgDecimation>
</Generic>
<LAMA_Specific>
<Switches>
<Apply_Fine_Slant_Range>
<Description>Apply the fine slant range
correction</Description>
<Value>On</Value>
</Apply_Fine_Slant_Range>
<Apply_Coarse_Slant_Range>
<Description>Apply the integer coarse slant range
correction</Description>
<Value>On</Value>
</Apply_Coarse_Slant_Range>
<Apply_Doppler_Range>
```

```
<Description>Apply the Doppler range
correction</Description>
    <Value>On</Value>
</Apply_Doppler_Range>
<Force_Approx_Former>
    <Description></Description>
    <Value>On</Value>
</Force_Approx_Former>
<Force_Exact_Former>
    <Description></Description>
    <Value>Off</Value>
</Force_Exact_Former>
<Beam_Weighting>
    <Description>Fit determined from Doppler beam stack
power</Description>
    <Value>On</Value>
</Beam_Weighting>
<Beam_Weighting_Method>
    <Description>Method of Doppler beam stack weighting. A -
Uniform, B - Gaussian</Description>
    <Value>B</Value>
</Beam_Weighting_Method>
<Apply_Beam_Weights>
    <Description>Apply Doppler beam weight stack
t</Description>
    <Value>Off</Value>
</Apply_Beam_Weights>
<Threshold_Beam_Power>
    <Description></Description>
    <Value>On</Value>
</Threshold_Beam_Power>
<Use_Internal_Noise_Power>
    <Description>Noise floor determined internal to
specialised processor (On). Otherwise on-board value used (Off)</Description>
    <Value>On</Value>
</Use_Internal_Noise_Power>
<QI_Toggle>
    <Description>Toggle I and Q complex samples</Description>
    <Value>Off</Value>
</QI_Toggle>
<Fix_Processed_SPs>
    <Description>The number of FBR records to process (-1
signifies all records)</Description>
    <Value>-1</Value>
</Fix_Processed_SPs>
<Fix_Breakpoint_SP_Start>
    <Description>The first FBR record to output (-1 signifies
all)</Description>
    <Value>-1</Value>
</Fix_Breakpoint_SP_Start>
<Fix_Breakpoint_SP_Stop>
    <Description>The last FBR record to output (-1 signifies
all)</Description>
    <Value>-1</Value>
</Fix_Breakpoint_SP_Stop>
<Anti_Alias_Power_Echoes>
    <Description>NO LONGER USED: Switch to turn on/off anti
aliased power echo determination</Description>
    <Value>Off</Value>
</Anti_Alias_Power_Echoes>
<Apply_Azimuth_Cal_Correction>
    <Description>Switch on/off application of azimuth impulse
resonse correction</Description>
    <Value>Off</Value>
</Apply_Azimuth_Cal_Correction>
<Apply_P_A_Cal_Correction>
    <Description>Switch on/off application of phase difference
and amplitude w.r.t frequency correction</Description>
    <Value>Off</Value>
</Apply_P_A_Cal_Correction>
<Steer_Beams>
    <Value>On</Value>
</Steer_Beams>
```

```

    <Remove_I_Q_Bias>
      <Value>On</Value>
    </Remove_I_Q_Bias>
    <Range_Compression>
      <Value>On</Value>
    </Range_Compression>
    <Beam_Formation>
      <Value>On</Value>
    </Beam_Formation>
    <Apply_Inst_Delay_Correction>
      <Value>Off</Value>
    </Apply_Inst_Delay_Correction>
    <Apply_Int_Phase_Diff_Corr>
      <Value>Off</Value>
    </Apply_Int_Phase_Diff_Corr>
    <Skip_L1_Records>
      <Value>0</Value>
    </Skip_L1_Records>
    <Reverse_Phase_Diff>
      <Value>Off</Value>
    </Reverse_Phase_Diff>
    <Reverse_Baseline>
      <Value>Off</Value>
    </Reverse_Baseline>
    <Interpolate_Orientation>
      <Value>Off</Value>
    </Interpolate_Orientation>
    <Apply_Azimuth_Hamming>
      <Value>On</Value>
      <Description>Apply a hamming window to time domain burst
prior to azimuth FFT</Description>
    </Apply_Azimuth_Hamming>
    <Apply_Range_Hamming>
      <Value>On</Value>
      <Description>Apply a hamming window to time domain beams
prior to range FFT</Description>
    </Apply_Range_Hamming>
    <Apply_Roll_Correction>
      <Value>Off</Value>
      <Description>Apply phase difference correction to
compensate for the roll of aircraft</Description>
    </Apply_Roll_Correction>
    <Window_L1b_Echo>
      <Value>Off</Value>
      <Description>Select a set of level 1b waveform samples
about re-track echo point</Description>
    </Window_L1b_Echo>
    <OCOG_Remove_Noise_Floor>
      <Value>On</Value>
      <Description>Remove noise floor from echoes during OCOG
re-tracking</Description>
    </OCOG_Remove_Noise_Floor>
    <Retracker_Type>
      <Value>OCOG</Value>
      <Description>Retracker types (OCOG), (Threshold), (Model_1
not implemented)</Description>
    </Retracker_Type>
  </Switches>
  <Tunable_Constants>
    <Stack_Size>
      <Description>Maximum size of the stack for SARIn
mode</Description>
      <Value unit="Doppler beams">300</Value>
      <Min_Value>40</Min_Value>
      <Max_Value>150</Max_Value>
    </Stack_Size>
    <Burst_Store>
      <Description>Size of Level 1 Source packet store for SARIn
mode</Description>
      <Value unit="Level 1 Source packets">600</Value>
      <Min_Value>100</Min_Value>
      <Max_Value>500</Max_Value>
    </Burst_Store>

```



```
<Centre_Burst_Loc>
  <Description>Burst processing Location in Source packet
buffer for SARIn mode (Must be less than 0 and greater than burst store size)</Description>
  <Value unit="Level 1 Source packet">300</Value>
  <Min_Value>70</Min_Value>
  <Max_Value>350</Max_Value>
</Centre_Burst_Loc>
<Beam_Form_Threshold>
  <Description>Change in elevation between surface samples
used to switch between approximate and exact beam formation methods</Description>
  <Value unit="Metres">3.0000000000000000E+02</Value>
  <Min_Value>0.0</Min_Value>
  <Max_Value>1.E3</Max_Value>
</Beam_Form_Threshold>
<Initial_Angle>
  <Description>Initial angle to generate surface
samples</Description>
  <Value unit="Radians">+0.0</Value>
  <Min_Value>-0.001</Min_Value>
  <Max_Value>+0.001</Max_Value>
</Initial_Angle>
<Multi_Look_Angle_Start>
  <Description>Threshold angle to trigger multi-looking of
beams directed at any surface sample</Description>
  <Value unit="Deg">6.0</Value>
  <Min_Value>5.E-1</Min_Value>
  <Max_Value>7.E-1</Max_Value>
</Multi_Look_Angle_Start>
<Multi_Look_Angle_Stop>
  <Description>Threshold angle to trigger gathering of beams
directed at any surface sample</Description>
  <Value unit="Deg">6.0</Value>
  <Min_Value>5.E-1</Min_Value>
  <Max_Value>7.E-1</Max_Value>
</Multi_Look_Angle_Stop>
<Num_Sub_Stack_Beams>
  <Description>Number of Doppler beams to sub-stack in
generation of noise floor power</Description>
  <Value unit="Doppler beams">1</Value>
  <Min_Value>1</Min_Value>
  <Max_Value>10</Max_Value>
</Num_Sub_Stack_Beams>
<Noise_Range_Start>
  <Description>Range bin for start of noise floor power
computation</Description>
  <Value unit="Range bin">14</Value>
  <Min_Value>14</Min_Value>
  <Max_Value>25</Max_Value>
</Noise_Range_Start>
<Noise_Range_Stop>
  <Description>Range bin for end of noise floor power
computation</Description>
  <Value>25</Value>
  <Min_Value>14</Min_Value>
  <Max_Value>25</Max_Value>
</Noise_Range_Stop>
<Sigma_Threshold>
  <Description>Multiplier of the standard deviation for
noise thresholding</Description>
  <Value>3</Value>
  <Min_Value>1</Min_Value>
  <Max_Value>6</Max_Value>
</Sigma_Threshold>
<Power_Mult_Ch_1>
  <Description>Spare power multiplier for Channel
1</Description>
  <Value unit="unitless">1.0</Value>
  <Min_Value>1.E-30</Min_Value>
  <Max_Value>1.E30</Max_Value>
</Power_Mult_Ch_1>
<Power_Mult_Ch_2>
  <Description>Spare power multiplier for Channel
2</Description>
```



```
<Value unit="unitless">1.0</Value>
  <Min_Value>1.E-30</Min_Value>
  <Max_Value>1.E30</Max_Value>
</Power_Mult_Ch_2>
<Noise_Power_Mult_Ch_1>
  <Description>Noise power multiplier for Channel
1</Description>
  <Value unit="unitless">1.0</Value>
  <Min_Value>1.E-30</Min_Value>
  <Max_Value>1.E30</Max_Value>
</Noise_Power_Mult_Ch_1>
<Noise_Power_Mult_Ch_2>
  <Description>Noise power multiplier for Channel
2</Description>
  <Value unit="unitless">1.0</Value>
  <Min_Value>1.E-30</Min_Value>
  <Max_Value>1.E30</Max_Value>
</Noise_Power_Mult_Ch_2>
<Echoes_Per_Burst_1_Hz>
  <Description>Number of echoes per burst in 1Hz pulse
limited echo generation</Description>
  <Value unit="Echoes">64</Value>
  <Min_Value>1</Min_Value>
  <Max_Value>64</Max_Value>
</Echoes_Per_Burst_1_Hz>
<L1_HRB>
  <Description>Number of SAR/SARIn FBR high rate blocks
(HRB) per record</Description>
  <Value unit="HRB">20</Value>
  <Min_Value>20</Min_Value>
  <Max_Value>20</Max_Value>
</L1_HRB>
<L1B_Blocks_Per_Record>
  <Description>Number of SAR/SARIn FBR samples per
record</Description>
  <Value unit="Samples">20</Value>
  <Min_Value>20</Min_Value>
  <Max_Value>20</Max_Value>
</L1B_Blocks_Per_Record>
<L1b_Max_Product_Power>
  <Description>Maximum value of L1b processed power
echo</Description>
  <Value unit="Counts">65535.0</Value>
  <Min_Value>65535.0</Min_Value>
  <Max_Value>65535.0</Max_Value>
</L1b_Max_Product_Power>
<Datation_Gap_Restart>
  <Description>Time lapse between samples used to re-start
SARIN processing</Description>
  <Value unit="Seconds">1.0</Value>
  <Min_Value>1.E-3</Min_Value>
  <Max_Value>10.0</Max_Value>
</Datation_Gap_Restart>
<OCOG_Start>
  <Description>Start range bin for OCOG calculation (0=first
range bin)</Description>
  <Value unit="Range bin">50</Value>
</OCOG_Start>
<OCOG_Stop>
  <Description>End range bin for OCOG calculation (0=first
range bin)</Description>
  <Value unit="Range bin">1000</Value>
</OCOG_Stop>
<OCOG_Retrack_Threshold>
  <Description>Retrack threshold min=0,
max=1.0</Description>
  <Value>0.8</Value>
</OCOG_Retrack_Threshold>
<OCOG_Default_Range>
  <Description>If the re-tracker fails the out range is
fixed to this value</Description>
  <Value unit="Meters">-99999.999</Value>
</OCOG_Default_Range>
```



```
<OCOG_Upper_Boundary>
  <Value unit="">3900</Value>
  <Description></Description>
</OCOG_Upper_Boundary>
<OCOG_Lower_Boundary>
  <Description></Description>
  <Value unit="">200</Value>
</OCOG_Lower_Boundary>
<OCOG_Echo_Width_Threshold>
  <Description>Echo width threshold that will trigger flag in
waveform group</Description>
  <Value unit="bin">20.0</Value>
</OCOG_Echo_Width_Threshold>
<OCOG_Noise_Floor_Start>
  <Description>If noise floor is to be removed from echoes
during ocog re-tracking then what is the start range bin for this computation</Description>
  <Value unit="bin">10</Value>
</OCOG_Noise_Floor_Start>
<OCOG_Noise_Floor_Stop>
  <Description>If noise floor is to be removed from echoes
during ocog re-tracking then what is the stop range bin for this computation</Description>
  <Value unit="bin">50</Value>
</OCOG_Noise_Floor_Stop>
<OCOG_Noise_Floor_Sigma_Factor>
  <Description>If noise floor is to be removed the threshold
level is x standard deviations above the mean power</Description>
  <Value unit="standard deviations">3.0</Value>
</OCOG_Noise_Floor_Sigma_Factor>
<IQ_Bias_Remove_Min>
  <Description>The minimum time domain echo sample number to
start calculation of I and Q waveform biases</Description>
  <Value unit="Sample">760</Value>
</IQ_Bias_Remove_Min>
<IQ_Bias_Remove_Max>
  <Description>The maximum time domain echo sample number
to end calculation of I and Q waveform biases</Description>
  <Value unit="Sample">767</Value>
</IQ_Bias_Remove_Max>
<Yaw_Threshold>
  <Value unit="Deg">1.0</Value>
  <Description>Threshold to trigger MCD flag if angle is
exceeded</Description>
</Yaw_Threshold>
<Roll_Threshold>
  <Value unit="Deg">1.0</Value>
  <Description>Threshold to trigger MCD flag if angle is
exceeded</Description>
</Roll_Threshold>
<Pitch_Threshold>
  <Value unit="Deg">1.0</Value>
  <Description>Threshold to trigger MCD flag if angle is
exceeded</Description>
</Pitch_Threshold>
<Yaw_SD_Threshold>
  <Value unit="Deg">0.3</Value>
  <Description>Standard deviation threshold to trigger MCD
flag if angle is exceeded</Description>
</Yaw_SD_Threshold>
<Roll_SD_Threshold>
  <Value unit="Deg">0.3</Value>
  <Description>Standard deviation threshold to trigger MCD
flag if angle is exceeded</Description>
</Roll_SD_Threshold>
<Pitch_SD_Threshold>
  <Value unit="Deg">0.3</Value>
  <Description>Standard deviation threshold to trigger MCD
flag if angle is exceeded</Description>
</Pitch_SD_Threshold>
<L1b_Wfm_Length>
  <Value unit="Range bin">1024</Value>
  <Description>The number of range bins stored in level 1b
file</Description>
</L1b_Wfm_Length>
```

```
<Max_Tracker_Var_Over_Stack>
  <Value unit="Range bin">50</Value>
  <Description>if tracker varies significantly over stack
the stack needs to be rejected. This parameter is used to determine the cut off point at which
the tracker variation is such it could cause excessive use of memory</Description>
</Max_Tracker_Var_Over_Stack>
</Tunable_Constants>
<Breakpoint_Files>
  <BKPLAASOAT>Off</BKPLAASOAT>
  <BKPLAASSUS>On</BKPLAASSUS>
  <BKPLAASAEL>On</BKPLAASAEL>
  <BKPLAASGDF>Off</BKPLAASGDF>
  <BKPLAASCDF>Off</BKPLAASCDF>
  <BKPLAASSSS>Off</BKPLAASSSS>
  <BKPLAASPF>Off</BKPLAASPF>
  <BKPLAASSBR>Off</BKPLAASSBR>
  <BKPLAASPBS>Off</BKPLAASPBS>
  <BKPLAASABF>Off</BKPLAASABF>
  <BKPLAASAPS>Off</BKPLAASAPS>
  <BKPLAASLES>On</BKPLAASLES>
  <BKPLAASUPT>Off</BKPLAASUPT>
  <BKPLAASRAC>Off</BKPLAASRAC>
  <BKPLAASSLA>Off</BKPLAASSLA>
  <BKPLAASRBU>Off</BKPLAASRBU>
  <BKPLAASDPW>Off</BKPLAASDPW>
  <BKPLAASFBO>Off</BKPLAASFBO>
  <BKPLAASF1B>Off</BKPLAASF1B>
  <BKPLAASLOG>Off</BKPLAASLOG>
  <BKPLAASINT>Off</BKPLAASINT>
  <BKPLAASBED>Off</BKPLAASBED>
  <BKPLAASHDO>Off</BKPLAASHDO>
  <BKPLAASF1_>Off</BKPLAASF1_>
  <BKPLAASFIF>Off</BKPLAASFIF>
  <BKPLAASFAT>Off</BKPLAASFAT>
  <BKPLAASMUL>Off</BKPLAASMUL>
  <BKPLAASJP1>Off</BKPLAASJP1>
  <BKPLAASJP2>Off</BKPLAASJP2>
  <BKPLAASFFT>Off</BKPLAASFFT>
</Breakpoint_Files>
</LAMA_Specific>
</LAM_A>
</Ipfl_Conf>
```

6.2. ASIRAS Processor Database

The ASIRAS processor database with respect to ASIRAS processor version 04.02 is attached. This file contains parameterer describing the instrument and on echo burst sizes. Some parameter arrays not used in the actual processing have been removed.

```
<?xml version="1.0" ?>
- <IPF_Database>
- <IPF_Database_Header>
- <Fixed_Header>
  <File_Name>AS_OPER_ASI_DBASE__20070329T000000_20070501T999999_0001.XML</File_Name>
  <File_Description>ASIRAS IPF Data Base: Instrument constants used by the Pre and level 1b
processors</File_Description>
  <Notes>Version 3 contains new LAM mode parameters. Version 4: GPS time tag bias added Version
8: Centre of measurements moved to centre of ASIRAS baseline Version 9: Following PRF change to
2.5 KHz LAM phase corrections require update for 60004 clock cycle related phase error. Version 10:
Following Corrections to hardware - cycle sampling has apparently been corrected*****USE
EARLIER DATABASE FOR PRE 2007 UPGRADE LAM WITH FREQ DEPENDENT PHASE
CORRECTIONS</Notes>
  AS_OPER_ASI_DBASE__20070329T000000_20070501T999999_0001.XML: LAM changed to 64
pulses per burst.
  <Mission_Code>AS</Mission_Code>
  <File_Class>OPER</File_Class>
  <File_Type>ASI_DBASE_</File_Type>
  <File_Version>0001</File_Version>
```

```
- <Source>
<System>ASIRAS</System>
<Creator>Robert Cullen</Creator>
<Creator_Version>00.01</Creator_Version>
<Creation_Date>2007-08-30T12:10:00</Creation_Date>
</Source>
</Fixed_Header>
+ <Variable_Header>
<MPH />
<SPH />
</Variable_Header>
</IPF_Database_Header>
- <Data_Block type="xml">
- <G_A1>
<Description>One way gain of antenna 1</Description>
<Value unit="10-2 dB">2500</Value>
<Note />
</G_A1>
- <G_A2>
<Description>One way gain of antenna 2</Description>
<Value unit="10-2 dB">2500</Value>
<Note />
</G_A2>
- <Antenna_Baseline>
<Description>Antenna Phase Centres Separation</Description>
<Value unit="m">0.760e0</Value>
<Note />
</Antenna_Baseline>
- <Internal_Phase_Correction>
<Description>Internal phase difference correction</Description>
<Value unit="rad">0.0</Value>
</Internal_Phase_Correction>
- <External_Phase_Correction>
<Description>External phase difference correction</Description>
<Value unit="rad">0.0</Value>
</External_Phase_Correction>
+ <LAM_Phase_Corrections>
- <List_of_Corrs count="6">
<Note>LAM frequency offset phase corrections per frequency (elevation) setting. These parameters shall all be zero following 29 March 2007 hardware upgrade. First phase correction for 20MHz offset with following values at 20Mhz steps to 120MHz</Note>
<LAM_Freq_Offset_Phase_Corr unit="micro-rad">0.0</LAM_Freq_Offset_Phase_Corr>
<LAM_Freq_Offset_Phase_Corr unit="micro-rad">0.0</LAM_Freq_Offset_Phase_Corr>
<LAM_Freq_Offset_Phase_Corr unit="micro-rad">0.0</LAM_Freq_Offset_Phase_Corr>
<LAM_Freq_Offset_Phase_Corr unit="micro-rad">0.0</LAM_Freq_Offset_Phase_Corr>
<LAM_Freq_Offset_Phase_Corr unit="micro-rad">0.0</LAM_Freq_Offset_Phase_Corr>
<LAM_Freq_Offset_Phase_Corr unit="micro-rad">0.0</LAM_Freq_Offset_Phase_Corr>
</List_of_Corrs>
</LAM_Phase_Corrections>
+ <LAMA_Phase_Corrections>
- <List_of_Corrs count="25">
<Note>LAM frequency offset phase corrections per frequency (elevation) setting. These parameters shall all be zero following 29 March 2007 hardware upgrade. First phase correction for 20MHz offset with following values at 5Mhz steps to 120MHz</Note>
<LAMA_Freq_Offset_Phase_Corr unit="micro-rad">0.0</LAMA_Freq_Offset_Phase_Corr>
</List_of_Corrs>
</LAMA_Phase_Corrections>
- <Burst_Phase_Rx1_GC>
<Description>128 Pulse to Pulse Phase Correction terms for Rx1</Description>
+ <List_of_Phase_Val count="128">
<Phase_Val unit="micro-rad">0.0</Phase_Val>
</List_of_Phase_Val>
```

```
<Note>Array of 128x1 phase values.</Note>
</Burst_Phase_Rx1_GC>
- <Burst_Amplitude_Rx1_GC>
  <Description>128 Pulse to Pulse Amplitude Correction terms for Rx1</Description>
+ <List_of_Amplitude_Val count="128">
  </List_of_Amplitude_Val>
  <Note>Array of 128x1 amplitude values.</Note>
  </Burst_Amplitude_Rx1_GC>
- <Burst_Phase_Rx2_GC>
  <Description>128 Pulse to Pulse Phase Correction terms for Rx2</Description>
+ <List_of_Phase_Val count="128">
  <Phase_Val unit="micro-rad">0.0</Phase_Val>
  </List_of_Phase_Val>
  <Note>Array of 128x1 phase values.</Note>
  </Burst_Phase_Rx2_GC>
- <Burst_Amplitude_Rx2_GC>
  <Description>128 Pulse to Pulse Amplitude Correction terms for Rx1</Description>
+ <List_of_Amplitude_Val count="128">
  </List_of_Amplitude_Val>
  <Note>Array of 128x1 amplitude values.</Note>
  </Burst_Amplitude_Rx2_GC>
- <AGC_Table_Rx1_GC>
  <Description>Corrected AGC values for Rx1</Description>
  <Note>Array of 100 values</Note>
+ <List_of_AGC_AGC_1 count="100">
  <AGC_1 unit="dB">0.0</AGC_1>
  <AGC_1 unit="dB">1.0</AGC_1>
  </List_of_AGC_AGC_1>
  </AGC_Table_Rx1_GC>
- <AGC_Table_Rx2_GC>
  <Description>Corrected AGC values for Rx2</Description>
  <Note>Array of 100 values</Note>
+ <List_of_AGC_AGC_2 count="100">
  <AGC_2 unit="dB">0.0</AGC_2>
  <AGC_2 unit="dB">1.0</AGC_2>
  </List_of_AGC_AGC_2>
  </AGC_Table_Rx2_GC>
- <Instrument_Delay_Rx1>
  <Description>Channel 1 instrument path delay - Approximate value</Description>
  <Value unit="ps">0.0</Value>
  </Instrument_Delay_Rx1>
- <Instrument_Delay_Rx2>
  <Description>Channel 2 instrument path delay - Approximate value</Description>
  <Value unit="ps">190.0</Value>
  </Instrument_Delay_Rx2>
- <Datation_Bias>
  <Description>A datation bias added to FBR centre of burst times by level 1b processor</Description>
  <Value unit="s">0.0</Value>
  </Datation_Bias>
- <GPS_Time_Tag_Offset>
  <Description>A datation bias to added to the GPS time tag extracted from the ASIRAS measurement
log file</Description>
  <Value unit="s">0.0</Value>
  </GPS_Time_Tag_Offset>
- <Lambda>
  <Description>Radar Wavelength</Description>
  <Value unit="mm">22.0e0</Value>
  <Note />
  </Lambda>
+ <LPF_SARIN_Rx1_GC>
  <Description>256 correction values for LPF filter of Rx1(SARIN)</Description>
  <Note>Not currently used</Note>
  </LPF_SARIN_Rx1_GC>
```

+ <LPF_SARIN_Rx2_GC>
<Description>**256 correction values for LPF filter of Rx2 (SARIN)**</Description>
<Note>**Not currently used**</Note>
</LPF_SARIN_Rx2_GC>

+ <Phase_Difference_Corr_GC>
<Description>**256 phase diff correction values**</Description>
<Phase_Diff_Val unit="micro radian">**0.0000000000000000**</Phase_Diff_Val>
<Note />
</Phase_Difference_Corr_GC>

- <Sampling_Freq>
<Value unit="Hz">**37500000.0**</Value>
<Description>**Sampling frequency for uncompressed de-ramped echo**</Description>
</Sampling_Freq>

- <Sampling_Freq_LAMA>
<Value unit="Hz">**9375000.0**</Value>
<Description>**Sampling frequency for uncompressed de-ramped echo**</Description>
</Sampling_Freq_LAMA>

- <NIMP_SARIN>
<Description>**Number of Pulses in the SARIn Burst**</Description>
<Value unit="">**128**</Value>
<Note />
</NIMP_SARIN>

- <NIMP_LAM>
<Description>**Number of Pulses in the LAM Burst**</Description>
<Value unit="">**64**</Value>
<Note />
</NIMP_LAM>

- <T_PULSE_Rx_LAM>
<Description>**Rx Radar pulse length**</Description>
<Value unit="ps">**80000000.0**</Value>
<Note />
</T_PULSE_Rx_LAM>

- <T_PULSE_Rx_SARIN>
<Description>**Rx Radar pulse length**</Description>
<Value unit="ps">**4000000.0**</Value>
<Note />
</T_PULSE_Rx_SARIN>

- <Chirp_Slope_SARIN>
<Description>**Chirp Slope for 1 GHz chirp**</Description>
<Value unit="Mhz/us">**250.0**</Value>
<Note />
</Chirp_Slope_SARIN>

- <Ns_LAM>
<Description>**Number of samples in LAM mode**</Description>
<Value>**4096**</Value>
<Note />
</Ns_LAM>

- <Ns_LAMA>
<Description>**Number of samples in LAM-A mode**</Description>
<Value>**1024**</Value>
<Note />
</Ns_LAMA>

- <Ns_SARIN>
<Description>**Number of samples in SARIn mode**</Description>
<Value>**256**</Value>
<Note />
</Ns_SARIN>

- <Chirp_Slope_LAM>
<Description>**Chirp Slope for 1 GHz chirp**</Description>
<Value unit="Mhz/us">**12.5**</Value>
<Note />
</Chirp_Slope_LAM>

- <ADC_Mult>

```
<Description />
<Value unit=""> 1000.0</Value>
<Note />
</ADC_Mult>
- <Tx_Power_SARIN>
  <Description>Instrument Tx power in SARIn mode</Description>
  <Value unit="W"> 5.0</Value>
  <Note />
</Tx_Power_SARIN>
- <Rx_Total_Gain_1>
  <Description>Rx 1 total gain</Description>
  <Value unit="dB"> 25.7</Value>
  <Note>TBD: 22 dB LNA (P64 ASIRAS Design Description ASIRAS-RST-ADD-0001). 16dB 1st IF.
  Second stage gain missing (P.63 design doc) -6.3 dB (Loss Tx based on existing 1m cables) -6.0 dB
  (Lrx loss)</Note>
</Rx_Total_Gain_1>
- <Rx_Total_Gain_2>
  <Description>Rx 2 total gain</Description>
  <Value unit="dB"> 25.7</Value>
  <Note>TBD: 22 dB LNA (P64 ASIRAS Design Description ASIRAS-RST-ADD-0001). 16dB 1st IF.
  Second stage gain missing (P.63 design doc) -6.3 dB (Loss Tx based on existing 1m cables) -6.0 dB
  (Lrx loss)</Note>
</Rx_Total_Gain_2>
- <Noise_Figure_1>
  <Description>Rx1 Noise Figure Curve vs AGC</Description>
- <List_of_Rx1_Noise_Val count="62">
  <Noise_Val unit="10-2 dB" />
</List_of_Rx1_Noise_Val>
  <Note>Array of 62 values</Note>
</Noise_Figure_1>
- <Noise_Figure_2>
  <Description>Rx2 Noise Figure Curve vs AGC</Description>
- <List_of_Rx2_Noise_Val count="62">
  <Noise_Val unit="10-2 dB" />
</List_of_Rx2_Noise_Val>
  <Note>Array of 62 values</Note>
</Noise_Figure_2>
</Data_Block>
</IPF_Database>
```